



SEMESTER -3

CET201	MECHANICS OF SOLIDS	CATEGORY	L	T	P	CREDIT	Year of Introduction
		PCC	3	1	0	4	2019

Preamble:

Mechanics of solids is one of the foundation courses in the study of structural systems. The course provides the fundamental concepts of mechanics of deformable bodies and helps students to develop their analytical and problem solving skills. The course introduces students to the various internal effects induced in structural members as well as their deformations due to different types of loading. After this course students will be able to determine the stress, strain and deformation of loaded structural elements.

Prerequisite: EST 100 Engineering Mechanics

Course Outcomes: After the completion of the course the student will be able to

Course Outcome	Description of Course Outcome	Prescribed learning level
CO1	Recall the fundamental terms and theorems associated with mechanics of linear elastic deformable bodies.	Remembering
CO2	Explain the behavior and response of various structural elements under various loading conditions.	Understanding
CO3	Apply the principles of solid mechanics to calculate internal stresses/strains, stress resultants and strain energies in structural elements subjected to axial/transverse loads and bending/twisting moments.	Applying
CO4	Choose appropriate principles or formula to find the elastic constants of materials making use of the information available.	Applying
CO5	Perform stress transformations, identify principal planes/stresses and maximum shear stress at a point in a structural member.	Applying
CO6	Analyse the given structural member to calculate the safe load or proportion the cross section to carry the load safely.	Analysing

Mapping of course outcomes with program outcomes (Minimum requirement)

	PO1	PO2	PO3	PO4	PO5	PO6	PO7	PO8	PO9	PO10	PO11	PO12
CO1	1	-	-	-	-	-	-	-	-	-	-	-
CO2	2	1	-	-	-	-	-	-	-	-	-	-
CO3	3	2	-	-	-	-	-	-	-	-	-	-
CO4	3	2	-	-	-	-	-	-	-	-	-	-
CO5	3	2	-	-	-	-	-	-	-	-	-	-
CO6	3	3	1	-	-	-	-	-	-	-	-	-

Assessment Pattern

Bloom's Category	Continuous Assessment Tests		End Semester Examination
	1	2	
Remember	10	10	15
Understand	10	10	15
Apply	30	20	60
Analyse		10	10
Evaluate			
Create			

Mark distribution

Total Marks	CIE	ESE	ESE Duration
150	50	100	3 hours

Continuous Internal Evaluation Pattern:

Attendance : 10 marks
 Continuous Assessment Test (2 numbers) : 25 marks
 Assignment/Quiz/Course project : 15 marks

End Semester Examination Pattern: There will be two parts; Part A and Part B. Part A contain 10 questions with 2 questions from each module, having 3 marks for each question. Students should answer all questions. Part B contains 2 questions from each module of which student should answer any one. Each question carries 14 marks and can have maximum 2 sub-divisions.

Course Level Assessment (Sample) Questions**CO1: Recall the fundamental terms and theorems associated with mechanics of linear elastic deformable bodies.**

1. What is proportionality limit? What is its significance?
2. Sketch the stress-strain curve of mild steel and mark the salient points
3. What is Poisson's ratio?
4. What is Bulk modulus of Elasticity? Write the relationship between Bulk modulus of elasticity and Young's modulus of elasticity.
5. What is pure bending? Give an example.
6. What is point of contraflexure?
7. What are the limitations of Euler's formula to calculate the buckling load of slender columns.
8. What is strain energy?
9. What is complementary shear stress?
10. What are principal stresses and principal planes?

CO2: Explain the behavior and response of various structural elements under various loading conditions.

1. Explain how the deformation of an axially loaded bar with uniformly varying cross section is calculated?
2. Explain the behavior of mild steel under gradually increasing tensile load.
3. Explain the effect of temperature change on a composite bar made of two materials.
4. How do you compute the maximum stress induced in a bar due to impact load?
5. Explain the concept of BM and SF in beams, with the help of a cantilever beam subjected to uniformly distributed load over the whole span.
6. List three important assumptions used in the theory of pure bending and explain their significance.
7. Explain the behavior of slender columns under axial compressive load.
8. Distinguish between short and long columns with reference to their behavior under axial compression.
9. Explain how the limitation of Euler's formula to calculate buckling load of columns is addressed in Rankine's formula.

CO3: Apply the principles of solid mechanics to calculate internal stresses/strains, stress resultants and strain energies in structural elements subjected to axial/transverse loads and bending/twisting moments.

1. A steel flat of cross section $25 \text{ mm} \times 6 \text{ mm}$ carries a tensile load of 12 kN . Find the stress induced in the cross section. If a circular hole of diameter 12 mm is made (normal to the flat surface), find the maximum stress induced in the cross section.
2. The bar ABC shown in figure is made of steel and has circular cross section. The bar BD is rigid. Find the stresses in portions AB and BC and the vertical deflection at C. Take $E = 210 \text{ GPa}$.

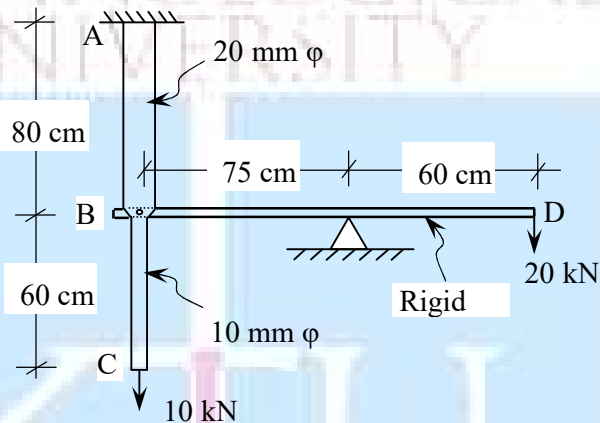

3. A rigid bar AB of length 100 cm, hinged at one end is supported by a steel rod and a copper wire as shown. Find the stresses induced in the rod and wire due to a downward load acting at 70 cm from the hinged end of the bar. Calculate the vertical deflection at B also. Modulus of elasticity of steel and copper are 200 GPa and 80 GPa respectively. Neglect the weight of the rigid bar.

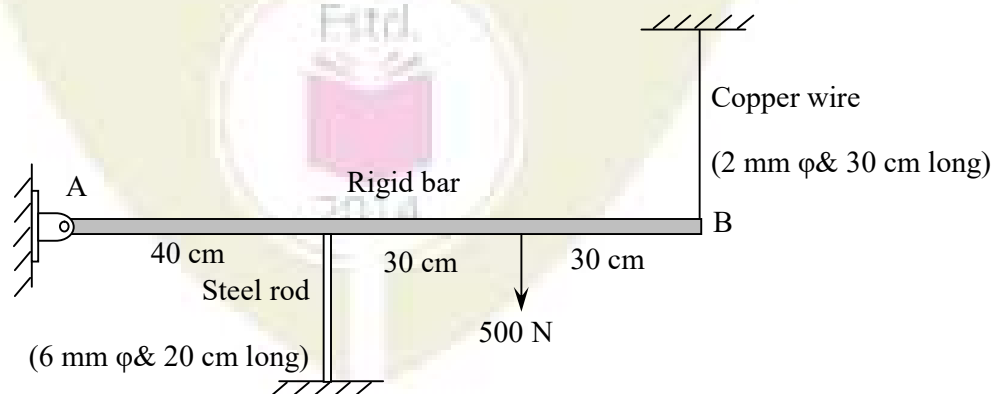

4. A 32 mm diameter steel bar is subjected to forces as shown in figure. Find the value of P necessary for equilibrium and stresses in different segments. Also calculate the final length of the bar. Take $E = 200 \text{ GPa}$.

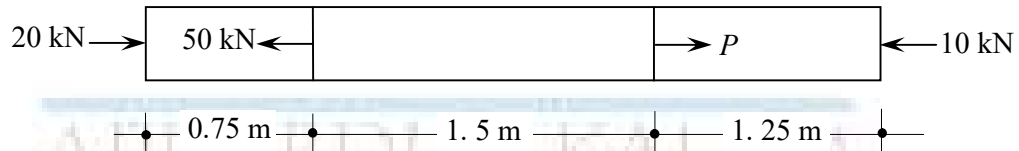

4. A cylindrical bar with two sections of lengths 50 cm and 25 cm, and diameters 20 mm and 15 mm respectively is subjected to an axial pull such that the maximum stress is 150 MN/m^2 . Calculate the strain energy stored in the bar. $E=200 \text{ GN/m}^2$
5. Draw the SFD and BMD of the beam shown.

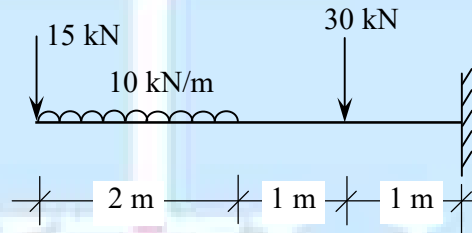

6. Figure shows the cross section of a beam. Find the stresses (both magnitude and nature) at points A,B,C,D,E and F, if the section carries a BM of 12 kNm. Draw the variation of stress across the cross section. Also calculate the shear stress at these points if the cross section carries a SF of 50 kN.

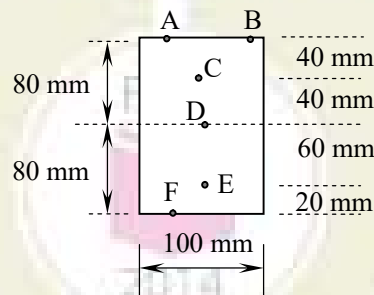

CO4: Choose appropriate principles or formula to find the elastic constants of materials making use of the information available.

1. A concrete cylinder of diameter 150 mm and height 300 mm is tested under compression. It was found that the diameter was increased by 0.0102 mm and the height was decreased by 0.165 mm under the action of a compressive load of 200 kN. Calculate the modulus of elasticity, Poisson's ratio, bulk modulus and shear modulus of concrete.

2. A tension test is carried out on a mild steel bar of 10 mm diameter. The bar yields under a load of 20 kN, it reaches a maximum load of 40 kN and breaks at 25 kN. The diameter of the bar at breaking was found to be 7 mm. The increase in length of the bar over a gauge length of 50 mm was found to be 0.029 mm under a load of 10 kN. Estimate (a) Young's modulus, (b) yield strength, (c) ultimate strength and (d) actual breaking strength

CO5: Perform stress transformations, identify principal planes/stresses and maximum shear stress at a point in a structural member.

1. A bar of 12 mm diameter carries an axial pull of 15 kN. Find the normal and shear stress on a plane inclined at 60° with the axis of the bar. What is the maximum shear stress induced in the bar and the inclination of the corresponding plane?
2. At a certain point in a strained material, the stresses on two planes at right angles to each other are 50 MPa (tensile) and 80 MPa (compressive). They are accompanied by a shear stress of magnitude 20 MPa. Find the principal stresses and locate their planes. Also find the maximum shear stress and resultant stress on the plane of maximum shear stress.

CO6: Analyse the given structural member to calculate the safe load or proportion the cross section to carry the load safely.

1. A timber beam 150 mm \times 200 mm is used as a simply supported beam of span 3 m. Find the maximum uniformly distributed load that can be applied in addition to a concentrated load of 5 kN acting at the mid span, if the maximum bending stress in the beam is not to exceed 8 N/mm^2 . Neglect self weight of beam.
2. A 3 m long cantilever beam of rectangular section is required to carry a udl of 10 kN/m over the whole span. If the maximum bending stress is limited to 12 N/mm^2 , find the dimensions of the cross section assuming depth to width ratio as 2.
3. A cast iron test beam 25 mm square in section and 700 mm long is simply supported at ends. It fails under a central load of 2300 N. What load at the free end will break a cantilever of the same material 50 mm wide \times 100 mm deep and 1500 mm long?
4. A solid circular shaft transmits 80 kW power at 190 rpm. Calculate the diameter of the shaft if the twist in the shaft is not to exceed 1° in 2 m length of shaft and shear stress is limited to 60 MPa. Take $G = 100 \text{ GPa}$.

SYLLABUS

Module – 1

Review of statics, Concept of stress and strain – types, Stress – strain relation - Hooke's law, Young's modulus of elasticity.
 Stress-strain diagram of mild steel.
 Factor of safety, working stress.
 Axially loaded bars with uniform cross section–stress, strain and deformation.
 Deformation of axially loaded bars with varying cross section and bars with varying axial loads.
 Statically indeterminate systems (number of unknowns restricted to two).

Module – 2

Temperature effects, temperature stress in composite bars.
 Shear stress and shear strain, Modulus of rigidity, simple shear, punching shear.
 Lateral strain, Poisson's ratio, volumetric strain.
 Bulk modulus of elasticity, relationships between elastic constants.
 Strain energy – concept. Strain energy due to normal stress.
 Strain energy in bars carrying axial loads.
 Instantaneous stress in bars due to gradual, sudden and impact loads. Strain energy due to shear stress.
 Stresses in thin cylinders and spheres due to internal pressure.

Module – 3

Beams – different types. Types of loading on beams. Concept of bending moment and shear force.
 Relationship between intensity of load, shear force and bending moment.
 Shear force and bending moment diagrams of cantilever beams, simply supported beams and overhanging beams for different type of loads. Point of contraflexure.

Module – 4

Theory of simple bending, assumptions and limitations.
 Calculation of normal stress in beams, moment of resistance
 Shear stress in beams.
 Beams of uniform strength.
 Strain energy due to bending – calculation of strain energy in beams.
 Differential equation for calculating the deflection of beams. (Introduction and demonstration only.
 Students are not expected to solve deflection problems.)

Module – 5

Stresses on inclined sections for uniaxial and biaxial stress fields.
 Principal stresses and principal planes in 2D problems, maximum shear stress.
 Strains along principal directions.
 Mohr's circle of stress for 2D problems.
 Short columns – direct and bending stress. Kern of a section.
 Slender columns – Euler's buckling load, slenderness ratio, limitation of Euler's formula.
 Rankine's formula.
 Torsion of circular and hollow circular shafts, Power transmitted by circular shafts and hollow circular shafts. Strain energy due to torsion.

Text Books:

1. H. J. Shah and S. B. Junnarkar, Mechanics of Structures Vol - I, Charotar Publishing House.
2. R. K. Bansal, A Text book of Strength of Materials, Laxmi Publications (P) Ltd, New Delhi.
3. B. C. Punmia, Ashok K. Jain, Arun Kumar Jain, Mechanics of Materials, Laxmi Publications (P) Ltd, New Delhi.

References:

1. Egor P. Popov, Engineering Mechanics of Solids, Prentice Hall International Series.
2. James M Gere, S.P. Timoshenko, Mechanics of Materials, CBS Publishers and Distributors, New Delhi.
3. R.C. Hibbeler, Mechanics of Materials (edn.10), Pearson
4. S. Ramamrutham and R. Narayanan, Strength of Materials, Dhanpat Rai Publishing Co (P) Ltd.
5. Rattan, Strength of Materials, McGraw Hill Education India.

Lecture Plan –Mechanics of Solids

<i>Module</i>	<i>Topic</i>	<i>Course Outcomes addressed</i>	<i>No. of Lectures</i>
1	Module I : Total lecture hours : 8		
1.1	Review of statics – equilibrium conditions, free body diagrams, centroid, moment of inertia.	-	1
1.2	Concept of stress, types of stresses. Concept of strain ,types of strains. Stress – strain relation - Hooke’s law, Young’s modulus of elasticity.	CO1, CO2, CO4	1
1.3	Stress-strain ($\sigma - \epsilon$) diagram of mild steel – proportional limit, yield point, ultimate stress, fracture. True and engineering $\sigma - \epsilon$ curve, idealized $\sigma - \epsilon$ curves. Factor of safety, working stress.	CO1, CO2	1
1.4	Axially loaded bars with uniform cross section– calculation of stress, strain and deformation.	CO2, CO3	1
1.5	Deformation of axially loaded bars with varying cross section. Stepped bars, bars with tapering cross section	CO3	1
1.6	Deformation of axially loaded bars with varying axial loads – elongation of bars under self weight, elongation/contraction of uniform/stepped bars.	CO3	1
1.7	Statically indeterminate systems – analysis of axially loaded composite bars (with maximum two materials)	CO3, CO6	1
1.8	Analysis of indeterminate systems with axial load carrying members (number of unknowns restricted to two). (Example: Assessment Level Question 3 of CO3)	CO3, CO6	1

2	Module II : Total lecture hours : 8		
2.1	Temperature effects, temperature stress in composite bars.	CO2, CO3	1
2.2	Shear stress and shear strain, Modulus of rigidity, simple shear, punching shear.	CO1, CO2, CO3, CO4	1
2.3	Lateral strain, Poisson's ratio, volumetric strain. Volumetric strain of rectangular bar, circular bar and sphere. Volumetric strain expressed in terms of strains along three mutually perpendicular directions.	CO2, CO3	1
2.4	Bulk modulus of elasticity, relationships between elastic constants.	CO1, CO4	1
2.5	Strain energy – concept. Resilience, modulus of resilience and proof resilience. Strain energy due to normal stress. Calculation of total strain energy in bars carrying axial loads. Strain energy due to shear stress.	CO1, CO2, CO3	2
2.6	Instantaneous stress in bars due to gradual, sudden and impact loads.	CO1, CO2, CO3	1
2.7	Stresses in thin cylinders and spheres due to internal pressure	CO1, CO2, CO3	1
3	Module III : Total lecture hours : 8		
3.1	Beams – different types. Types of loading on beams. Concept of bending moment and shear force. Shear force and bending moment diagrams.	CO1, CO2	1
3.2	Relationship between load, shear force and bending moment. Demonstration using simple examples.	CO1	1
3.3	Shear force and bending moment diagrams of cantilever beams subjected to point load, concentrated moments, uniformly distributed and uniformly varying loads.	CO2	2
3.4	Shear force and bending moment diagrams of simply supported beams subjected to point load, concentrated moment, uniformly distributed and uniformly varying loads.	CO2	2
3.5	Shear force and bending moment diagrams of overhanging beams subjected to point load, concentrated moment and uniformly distributed loads. Point of contraflexure.	CO1, CO2	2
4	Module IV : Total lecture hours : 9		
4.1	Theory of simple bending – derivation of equation, assumptions and limitations.	CO1, CO2	1
4.2	Variation of bending stress across the cross section. Maximum bending stress, section modulus, moment of resistance.	CO1, CO2	1
4.3	Calculation of normal stress in beams. Problems involving bending stress	CO3	1

4.4	Shear stress in beams – derivation of equation. Variation of shear stress across the cross section. (Derivation required for rectangular, circular and triangular sections only)	CO1, CO2	1
4.5	Calculation of shear stress- problems involving shear stress.	CO3	1
4.6	Calculation of allowable loads in beams based on bending stress and shear stress criteria.	CO6	1
4.7	Proportioning beam sections to carry given load without exceeding the allowable bending stress and/ shear stress. Beams of uniform strength.	CO6	1
4.8	Strain energy due to bending – calculation of strain energy in beams. (Cantilever and simply supported beams subjected to point load and uniformly distributed load)	CO1, CO2, CO3	1
4.9	Moment-curvature relation. Basic differential equation for calculating the deflection of beams. Simple example to calculate deflection of beams (such as cantilever beam with point load at free end) for demonstration purpose.	CO1	1
5	Module V : Total lecture hours : 12		
5.1	Stresses on inclined planes for uniaxial and biaxial stress fields. Element subjected to pure shear.	CO3	2
5.2	Principal stresses and principal planes in 2D problems, maximum shear stress. Strains along principal directions.	CO1, CO3, CO5	2
5.3	Mohr’s circle of stress for 2D problems.	CO3, CO5	1
5.4	Short columns – direct and bending stress. Kern of a section (concept only).	CO1,CO2, CO3	1
5.5	Slender columns –Buckling, Euler’s buckling load for columns with pinned ends. Eulers’ buckling load for columns with different end conditions (no derivation required). Effective length of columns with different end conditions.	CO1,CO2, CO3	2
5.6	Slenderness ratio, limitation of Euler’s formula. Rankine’s formula. Safe load calculation using Rankine’s formula (demonstration only).	CO1,CO2, CO3	1
5.7	Torsion of circular and hollow circular shafts, assumptions, derivation of torsion equation. Variation of stress across the cross section.Polar modulus.	CO1,CO2, CO3	1
5.8	Power transmitted by circular shafts and hollow circular shafts. Proportioning the shafts to transmit a given power based on shear stress and angle of twist considerations Strain energy due to torsion.	CO3, CO6	2

MODEL QUESTION PAPER

Reg.No.: _____

Name: _____

APJ ABDUL KALAM TECHNOLOGICAL UNIVERSITY
THIRD SEMESTER B.TECH DEGREE EXAMINATION

Course Code: CET201

Course Name: MECHANICS OF SOLIDS

Max. Marks: 100

Duration: 3 Hours

PART A

Answer all questions; each question carries 3 marks.

1. a) Define the terms (i) proportionality limit, (ii) ultimate stress (ii) working stress.
- b) Explain, how the deformation of an axially loaded bar with uniformly varying cross section is calculated?
- c) Explain the effect of temperature change on a composite bar made of two materials.
- d) What is Bulk modulus of Elasticity? Write the relationship between Bulk modulus of elasticity and Young's modulus of elasticity.
- e) What is the relationship between intensity of load, SF and BM?
- f) Explain the concept of BM and SF in beams, with the help of a cantilever beam subjected to uniformly distributed load over the whole span.
- g) What is pure bending? Give an example.
- h) List three important assumptions used in the theory of pure bending and their significance.
- i) What are principal stresses and principal planes?
- j) Distinguish between short and long columns with reference to their behavior under axial compression.

(10×3 marks = 30 marks)

PART B

Answer one full question from each module; each full question carries 14 marks.

Module I

2. A bar of circular cross section has three segments as shown in figure. The portion AB has a constant diameter of 25 mm. The portion BC has diameter 25 mm at B and tapers uniformly to diameter 'd' at C. The portion CD has a constant diameter of 'd'. The bar was found to elongate by 0.539 mm under an axial tension of 20 kN. Find the value of 'd'. Take Young's modulus of elasticity of the material as 200 GPa.

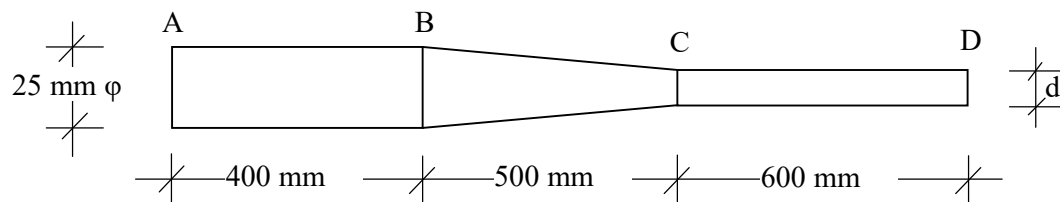

3. A steel rod of 25 mm diameter is placed in a hollow aluminium cylinder with internal diameter 30 mm and external diameter 40 mm. The steel rod projects 0.1 mm as shown. The bar carries a compressive force of 70 kN through a rigid bearing plate. Find the stresses in steel and aluminium bars. $E_s = 200 \text{ GPa}$ and $E_{al} = 120 \text{ GPa}$

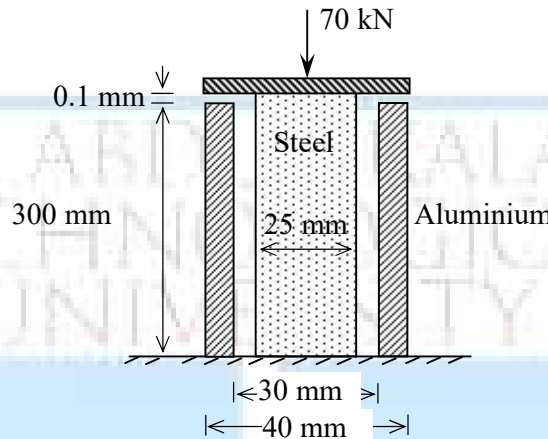

Module II

4. A concrete cylinder of diameter 150 mm and height 300 mm is tested under axial compression. It was found that the diameter was increased by 0.0102 mm and the height was decreased by 0.165 mm under the action of a compressive load of 200 kN. Calculate the modulus of elasticity, Poisson's ratio, bulk modulus and shear modulus of concrete.
5. A compound bar is made of a central steel plate 60 mm wide and 10 mm thick to which copper plates 40 mm wide and 5mm thick are rigidly connected on each side. The length of the bar at normal temperature is 1 m. If the temperature is raised by 80°C , determine the stress in each metal and the change in length. $E_s = 2 \times 10^5 \text{ N/mm}^2$, $\alpha_s = 12 \times 10^{-6} / ^\circ\text{C}$, $E_c = 1.05 \times 10^5 \text{ N/mm}^2$ and $\alpha_c = 17.5 \times 10^{-6} / ^\circ\text{C}$.

Module III

6. Draw the SFD and BMD of the beam loaded as shown in figure. Find the maximum BM and locate the point of maximum BM also.

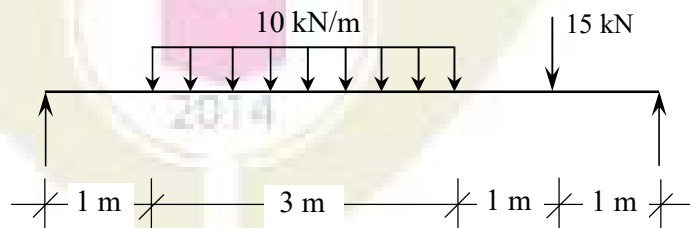

7. An overhanging beam is loaded as shown. Draw SFD and BMD. Locate the point of contraflexure also.

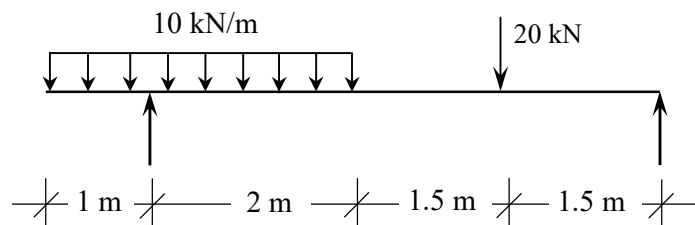

Module IV

8. a) A simply supported beam of triangular cross section, having width 160 mm and height 210 mm, carries a udl of 2 kN/m over a span of 4m. Find the maximum tensile and compressive stresses induced. Draw the variation of stress across the cross section. (10 marks)
- b) Calculate the total strain energy due to bending in a cantilever beam of span L carrying a point load W at its free end. (4 marks)
9. a) A timber beam 150 mm × 200 mm (width = 150 mm) is used as a simply supported beam of span 3 m. Find the maximum uniformly distributed load that can be applied in addition to a concentrated load of 5 kN acting at the mid span, if the maximum bending stress and shear stress in the beam are not to exceed 15 N/mm² and 2 N/mm² respectively. Neglect self weight of beam. (10 marks)
- b) What is beam of uniform strength? Give an example. (4 marks)

Module V

10. A point in a strained body is subjected to stresses as shown in figure. Find the principal stresses and maximum shear stress. Also locate the principal planes and planes of maximum shear stress, with respect to the vertical plane. Calculate the strains along the direction of the principal stresses also. Take $E = 200$ GPa and $\nu = 0.25$.

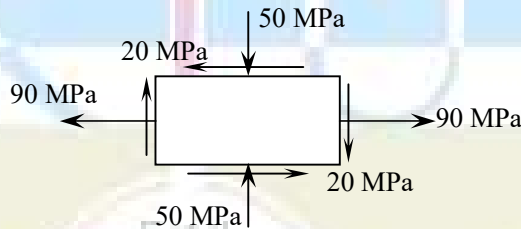

11. A solid circular shaft transmits 80 kW power at 190 rpm. Calculate the diameter of the shaft if the twist in the shaft is not to exceed 1° in 2 m length of shaft and shear stress is limited to 60 MPa. Take $G = 100$ GPa.

CET 203	Fluid Mechanics and Hydraulics	Category	L	T	P	Credit	Year of Introduction
		PCC	3	1	0	4	2019

Preamble: Goal of this course is to expose the students to the fundamental concepts of fluid mechanics, hydraulics of pipes and open channels and to enhance the problem solving skills. The concepts learned will help in applying them for the design of hydraulic structures and to real world fluid flow problems.

Pre-requisite: Elementary mathematics, concepts in engineering mechanics

Course outcome

After the course, the student will able to:

CO1	Recall the relevant principles of hydrostatics and hydraulics of pipes and open channels
CO2	Identify or describe the type, characteristics or properties of fluid flow
CO3	Estimate the fluid pressure, perform the stability check of bodies under hydrostatic condition
CO4	Compute discharge through pipes or estimate the forces on pipe bends by applying hydraulic principles of continuity, energy and/or momentum
CO5	Analyze or compute the flow through open channels, perform the design of prismatic channels

CET 203 Fluid Mechanics and Hydraulics		PO1	PO2	PO3	PO4	PO5	PO6	PO7	PO8	PO9	PO10	PO11	PO12
	CO1	2	2										
	CO2	2	2										
	CO3	3	3				1						
	CO4	3	3				1						
	CO5	3	3	2									

Assessment pattern

Bloom's Category	Continuous Assessment Tests		End Semester Examination (Marks)
	Test 1 (Marks)	Test 2 (Marks)	
Remember	5	5	15
Understand	10	10	15
Apply	20	20	40
Analyze	15	15	30

Evaluate			
Create			

Continuous Internal Evaluation Pattern:

Attendance	:	10 marks
Continuous Assessment Test(2 numbers)	:	25 marks
Assignment/Quiz/Course project	:	15 marks
Total	:	50 marks

End semester examination pattern – There will be two parts; Part A and Part B. Part A contain 10 questions with 2 questions from each module, having 3 marks for each question. Students should answer all questions. Part B contains 2 questions from each module of which student should answer any one. Each question can have maximum 2 sub-divisions and carry 14 marks.

Qn No	Question	Marks	Course outcome (CO) Assessed
Part A (Answer ALL Questions)			
1	Explain the method of estimation of hydrostatic force on curved surfaces	3	CO1
2	Compare the use of piezometer and manometer for pressure measurement	3	CO1
3	Explain the experimental method of determination of metacentric height	3	CO1
4	Define streamline, streakline and pathline	3	CO2
5	Explain the use and principle of Pitot tube	3	CO1
6	Obtain the discharge equation of a large rectangular orifice	3	CO2
7	Explain conveyance and section factor for uniform flow and their practical applications	3	CO1
8	Obtain the condition for maximum velocity through	3	CO1

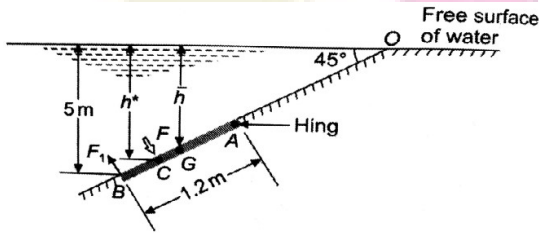
	circular channels		
9	State the assumptions involved in the derivation of dynamic equation of gradually varied low	3	CO1
10	Explain the classification of hydraulic jumps based on Froude's Number	3	CO1
	Part B (Answer ANY ONE FULL question from each module)		
	Module I		
11(a)	Differentiate gauge pressure, atmospheric pressure and absolute pressure	4	CO1
11(b)	A U-tube manometer is used to measure the pressure of water in a pipeline which is in excess of atmospheric. The left limb is connected to the pipeline and right limb is open to atmosphere. The free surface of mercury in the right limb is in level with the centre line of the pipe and the level difference of mercury in the limbs of the manometer is 20 cm. Compute the water pressure in the pipeline. If the pressure of water is increased by 50 %, compute the manometric reading.	10	CO3
12(a)	Obtain the expression for centre of pressure of a lamina placed in fluid in vertical position	4	CO1
12(b)	An inclined rectangular sluice gate AB 1.2m by 5m as shown in fig is installed to control the discharge of water. The end A is hinged. Determine the force normal to gate applied at B to open it. 	10	CO3
	Module II		
13(a)	Find the acceleration at (1, 2, 3) after 1 sec for a 3D flow given by $u=yz+t$, $v=xz-t$, $w=xy$	6	CO2
13(b)	Derive continuity equation in 3D Cartesian coordinates	8	CO1

14(a)	A solid cylinder 2 m in diameter and 2 m in length floats in water with its axis vertical. If the specific gravity of the material of the cylinder is 0.65, find the metacentric height and comment on the stability of the body	6	CO3
14(b)	Explain the stability conditions of floating bodies and submerged bodies	8	CO1
Module III			
15	Gasoline (specific gravity 0.82) flows at a rate of 215 l/s in upward direction through an inclined venturimeter fitted to a 300 mm diameter pipe. The venturimeter is inclined at 60° to vertical and its 150 mm diameter throat is 1.2 m from the entrance along its length. Pressure gauges inserted at the inlet and throat show pressures of 0.141 N/mm^2 and 0.077 N/mm^2 respectively. Compute the coefficient of discharge of the venturimeter. If instead of pressure gauges, the entrance and throat are connected to two limbs of a mercury u-tube manometer, determine the manometric reading.	14	CO4
16	A pipeline of 600 m diameter is 1.5 km long. To increase the discharge, another pipe of same diameter is introduced in parallel to the first pipe, for the second half of length. If $f=0.04$, and head at inlet is 300 mm, calculate the increase in discharge. Neglect minor losses.	14	CO4
Module IV			
17(a)	Explain the characteristics of velocity distribution in open channels	4	CO2
17(b)	A lined canal $n=0.014$ is of trapezoidal section with one side vertical and other with a slope of 1.5H:1 V. If the channel is to deliver $9 \text{ m}^3/\text{sec}$ when laid on a slope of 0.0002, calculate the dimensions of the efficient section that requires minimum lining.	10	CO5
18(a)	Obtain the discharge equation of a Cipoletti weir	4	CO2
18(b)	A 40 m long weir is divided into 12 equal bays by vertical posts, each 0.6 m wide. Using Francis formula, calculate the discharge over the weir if the head over the crest is 1.2 m and velocity of approach is 2 m/sec	10	CO5
Module V			
19 (a)	State the characteristics of M type profiles	4	CO2

19 (b)	A very wide rectangular channel carries a discharge of 8 cumecs per m width. The channel has a bed slope of 0.004 and Manning's roughness coefficient 0.015. Find the distance to a section where water depth is 0.9 m using single step method	10	CO5
20 (a)	Show that minimum specific force for a given discharge indicate the critical flow in open channels	4	CO2
20 (b)	The energy loss and Froude number after the jump in a horizontal rectangular channel are 9.00 and 0.12 respectively. Determine the depth before the jump will be and the power lost per m width of the channel	10	CO5

Model Question Paper

Reg No.:.....

QP CODE:.....

Name:.....

**APJ ABDUL KALAM TECHNOLOGICAL UNIVERSITY
THIRD SEMESTER B.TECH DEGREE EXAMINATION, MONTH & YEAR**

Course Code: CET203

Fluid Mechanics and Hydraulics

Max. Marks: 100

Duration: 3 hours

Part A**(Answer all questions; each question carries 3 marks)**

1. Explain the method of estimation of hydrostatic force on curved surfaces
2. Compare the use of piezometer and manometer for pressure measurement
3. Explain the experimental method of determination of metacentric height
4. Define streamline, streakline and pathline
5. Explain the use and principle of Pitot tube
6. Obtain the discharge equation of a large rectangular orifice
7. Explain conveyance and section factor for uniform flow and their practical applications
8. Obtain the condition for maximum velocity through circular channels
9. State the assumptions involved in the derivation of dynamic equation of gradually varied flow

10. Explain the classification of hydraulic jumps based on Froude's Number

(3 Marks x 10 = 30 Marks)

Part B

(Answer one full question from each module, each question carries 14 marks)

Module I

- 11 (a) Differentiate gauge pressure, atmospheric pressure and absolute pressure (4 Marks)

- (b) A U-tube manometer is used to measure the pressure of water in a pipeline which is in excess of atmospheric. The left limb is connected to the pipeline and right limb is open to atmosphere. The free surface of mercury in the right limb is in level with the centre line of the pipe and the level difference of mercury in the limbs of the manometer is 20 cm. Compute the water pressure in the pipeline. If the pressure of water is increased by 50 %, compute the manometric reading. (10 Marks)

OR

- 12.(a) Obtain the expression for centre of pressure of a lamina placed in fluid in vertical position (4 Marks)

- (b) An inclined rectangular sluice gate AB 1.2m by 5m as shown in fig is installed to control the discharge of water. The end A is hinged. Determine the force normal to gate applied at B to open it. (10 Marks)

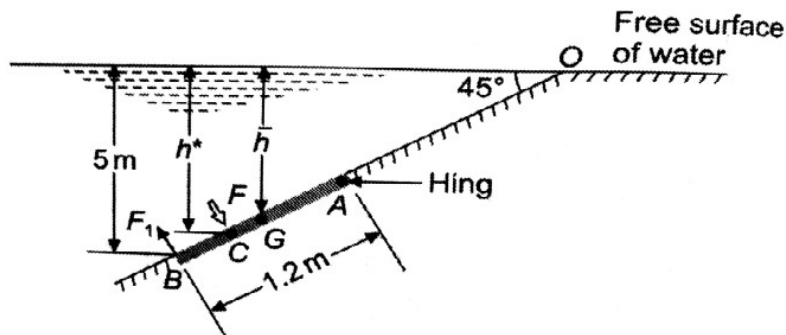

Module II

- 13.(a) Find the acceleration at (1, 2, 3) after 1 sec for a 3D flow given by $u=yz+t$, $v=xz-t$, $w=xy$

(6 Marks)

- (b) Derive continuity equation in 3D Cartesian coordinates

(8 Marks)

OR

14. (a) A solid cylinder 2 m in diameter and 2 m in length floats in water with its axis vertical. If the specific gravity of the material of the cylinder is 0.65, find the metacentric height and comment on the stability of the body. (6 Marks)
- (b) Explain the stability conditions of floating and submerged bodies (8 Marks)

Module III

15. Gasoline (specific gravity 0.82) flows at a rate of 215 l/s in upward direction through an inclined venturimeter fitted to a 300 mm diameter pipe. The venturimeter is inclined at 60° to vertical and its 150 mm diameter throat is 1.2 m from the entrance along its length. Pressure gauges inserted at the inlet and throat show pressures of 0.141 N/mm^2 and 0.077 N/mm^2 respectively. Compute the coefficient of discharge of the venturimeter. If instead of pressure gauges, the entrance and throat are connected to two limbs of a mercury u-tube manometer, determine the manometric reading. (14 Marks)

OR

16. A pipeline of 600 m diameter is 1.5 km long. To increase the discharge, another pipe of same diameter is introduced in parallel to the first pipe, for the second half of length. If $f=0.04$, and head at inlet is 300 mm, calculate the increase in discharge. Neglect minor losses. (14 Marks)

Module IV

- 17 (a) Explain the characteristics of velocity distribution in open channels (4 Marks)
- (b) A lined canal $n=0.014$ is of trapezoidal section with one side vertical and other with a slope of 1.5H:1 V. If the channel is to deliver $9 \text{ m}^3/\text{sec}$ when laid on a slope of 0.0002, calculate the dimensions of the efficient section that requires minimum lining. (10 Marks)

OR

- 18 (a) Obtain the discharge equation of a Cipoletti weir (4 Marks)
- (b) A 40 m long weir is divided into 12 equal bays by vertical posts, each 0.6 m wide. Using Francis formula, calculate the discharge over the weir if the head over the crest is 1.2 m and velocity of approach is 2 m/sec (10 Marks)

Module V

- 19 (a) State the characteristics of M type profiles (4 Marks)

- (b) A very wide rectangular channel carries a discharge of 8 cumecs per m width. The channel has a bed slope of 0.004 and Manning's roughness coefficient 0.015. Find the distance to a section where water depth is 0.9 m using single step method. (10 Marks)

OR

- 20.(a) Show that minimum specific force for a given discharge indicate the critical flow in open channels. (4 Marks)
- (b) The energy loss and Froude number after the jump in a horizontal rectangular channel are 9.00 and 0.12 respectively. Determine the depth before the jump will be and the power lost per m width of the channel. (10 Marks)

Course Code: CET203
Fluid Mechanics and Hydraulics
Syllabus

Module I

Introduction to the subject-Fluid properties (mass density, specific weight, viscosity, specific gravity), Classification of Fluids (prerequisite no questions from this section)
 Fluid statics-variation of pressure in a fluid, measurement of fluid pressure using piezometers and manometers, U-tube manometers, Forces on immersed plane placed vertical and inclined positions. Hydrostatic force on curved surfaces – Practical application of total pressure on spillway gates.

Module II

Buoyancy and Floatation: Buoyant force, Principle of floatation, stability of floating and submerged bodies, metacentre and metacentric height, analytical and experimental determination of metacentric height
 Hydrodynamics- Methods of describing fluid motion, Lagrangian and Eulerian methods, velocity and acceleration, types of fluid flow, description of fluid flow- streamline, pathline and streakline; continuity equation in one, two and three dimensions

Module III

Fluid kinetics-forces considered in describing fluid motion, Derivation of Bernoulli's equation by integration of Euler's equation along a streamline, kinetic energy correction factor, Applications of Bernoulli's equation- Venturimeter, Pitot tube and Orificemeter; Hydraulic

coefficients of orifices and their experimental determination, Discharge through small orifice and large rectangular orifices

Pipe flow- computation of major and minor losses in pipes, hydraulic gradient line and total energy line, pipes in series-equivalent pipe, flow through parallel pipes.

Module IV

Open channel flow – comparison between pipe flow and open channel flow, velocity distribution in open channels, types of channels, type of flow, geometric elements of channel section, uniform flow computations (Chezy's equation, Kutter's and Manning's formula); Most economical sections – rectangular, triangular and trapezoidal channels, condition for maximum discharge and maximum velocity through circular channels, conveyance and section factor
Flow measurement in channels – notches and weirs – Discharge computations using weirs-velocity of approach and end contraction, discharge equations of rectangular weir, triangular weir, trapezoidal and Cipoletti weir, submerged weir, broad crested weir.

Module V

Specific energy- specific energy diagram and discharge diagram, Critical flow and its computation.

Gradually varied flow- Dynamic equation of gradually varied flow-different forms, types and characteristics of water surface profiles in rectangular prismatic channels. Computation of length of water surface profiles by direct step method

Specific force, Rapidly varied flow-Hydraulic jump-conjugate or sequent depths, expression for sequent depths and energy loss for a hydraulic jump in horizontal rectangular channels, types uses and characteristics of hydraulic jump

Text Books

1. Modi P. N. and S. M. Seth, Hydraulics & Fluid Mechanics, S.B.H Publishers, New Delhi, 2002.
2. Subramanya K., Theory and Applications of Fluid Mechanics, Tata McGraw-Hill, 1993.
3. Subramanya K., Flow in Open channels, Tata McGraw-Hill, 2009.

References

1. Streeter.V.L. Fluid Mechanics, Mc Graw Hill Publishers.
2. Bruce R Munson, Donald F Young . Fundamentals of Fluid Mechanics, John Wiley & sons, 2011.
3. Jain A. K., Fluid Mechanics, Khanna Publishers, Delhi, 1996.
4. Joseph Katz, Introductory Fluid Mechanics, Cambridge University Press, 2015
5. Arora.K.R. Fluid Mechanics, Hydraulics and Hydraulic Machines, Standard Publishers, 2005.

6. Narasimhan S., A First Course in Fluid Mechanics, University Press (India) Pvt. Ltd., 2006.
7. Frank.M.White, Fluid Mechanics, Mc Graw Hill, 2013.
8. Mohanty.A.K. Fluid Mechanics, Prentice Hall, New Delhi, 2011
9. Narayana Pillai,N. Principles of Fluid Mechanics and Fluid Machines, University Press, 2011.
10. Kumar.D.N. Fluid Mechanics and Fluid power Engineering, S.K.Kataria & sons, 2013.

Course Code: CET203
Fluid Mechanics and Hydraulics
Course content and Schedule of lecture (sample)

Module	Topic	Course outcome addressed	No of Hours
Module I (9 Hours)			
1.1	Introduction to the subject-Fluid properties (mass density, specific weight, viscosity, specific gravity) Classification of Fluids	CO1	1
1.2	Fluid statics-fluid pressure and variation of pressure in a fluid, Pressure head	CO1	1
1.3	Measurement of pressure using piezometers and manometers	CO3	1
1.4	Problems on pressure measurement	CO3	1
1.5	Tutorial	CO3	1
1.6	Pressure head on immersed plane- vertical and inclined cases	CO3	1
1.7	Problems on estimation of pressure	CO3	1
1.8	Estimation of pressure force acting on curved surfaces	CO1	1
1.9	Tutorial	CO3	1
Module II (9 Hours)			
2.1	Buoyancy, buoyant force, principle of floatation, stability of submerged bodies	CO1	1
2.2	Stability of floating bodies, metacentre and metacentric height-analytical determination	CO1	1
2.3	Metacentric height- experimental determination, problems	CO3	1
2.4	Problems on buoyancy and floatation	CO3	1

2.5	Kinematics of fluids: Methods of describing fluid motion, Lagrangian and Eulerian methods, Types of fluid flow; Description of fluid motion-streamline, streakline and pathline	CO2	1
2.6	Velocity & Acceleration of fluid particle, convective and local acceleration	CO2	1
2.7	Problems on flow properties	CO2	1
2.8	Conservation of mass, Equation of continuity in 1D,2D and 3D	CO2	1
2.9	Tutorial	CO2	1
Module III (9 Hours)			
3.1	Introduction to fluid kinetics – forces acting; Euler’s equation of motion and integration of Euler’s equation of motion along a streamline- Bernoulli’s Equation, Energy correction factor	CO1	1
3.2	Applications of Bernoulli’s equation, Venturimeter and orifice meter, Problems	CO4	1
3.3	Problems	CO4	1
3.4	Flow through orifices: types of orifices, Experimental determination of Hydraulic coefficients	CO2	1
3.5	Flow over a sharp edged orifice, Flow through large rectangular orifice and submerged orifices	CO2	1
3.6	Pipe flow: Equations for determination of major and minor energy losses	CO1	1
3.7	Hydraulic gradient and total energy line; pipes in series and parallel	CO1	1
3.8,	Problems on discharge computation	CO4	1
3.9	Tutorial	CO4	1
Module IV (9 Hours)			
4.1	Introduction-difference between pipe flow and open channel flow- types of channels and flow, velocity distribution in open channels	CO1	1
4.2	Geometric elements of channels-computation for simple sections- Uniform flow; Derivation of Chezy’s equation	CO1	1
4.3	Manning’s and Kutter’s Equation, Concept of Conveyance and Section factor, problems	CO5	1
4.4	Problems		1
4.5	Most economical sections-conditions for rectangular, triangular and trapezoidal channels	CO5	1
4.6	Most economical circular channels, Problems	CO5	1
4.7	Flow measurement in channels- Types of weirs flow over rectangular and triangular sharp crested weir; Effect of end contraction and velocity of approach	CO5	1

4.8	Flow over a trapezoidal weir, Cipolletti weir, broad crested weir, submerged weirs	CO5	1
4.9	Tutorial	CO5	1
Module V (9 Hours)			
5.1	Specific energy, Specific energy diagram computation of critical depth	CO5	1
5.2	Problems	CO5	1
5.3	Gradually varied flow-Concept, Forms of GVF equations,	CO5	1
5.4	Types and Characteristics of water surface profiles	CO5	1
5.5	Problems	CO5	1
5.6	Computation of length of water surface profiles by direct step method, Problems	CO5	1
5.7	Specific force, Conjugate depths, Hydraulic jump- Derivation of sequent depth relation in rectangular channels	CO5	1
5.8	Characteristics, types and uses of hydraulic jump, Problems	CO5	1
5.9	Tutorial	CO5	1

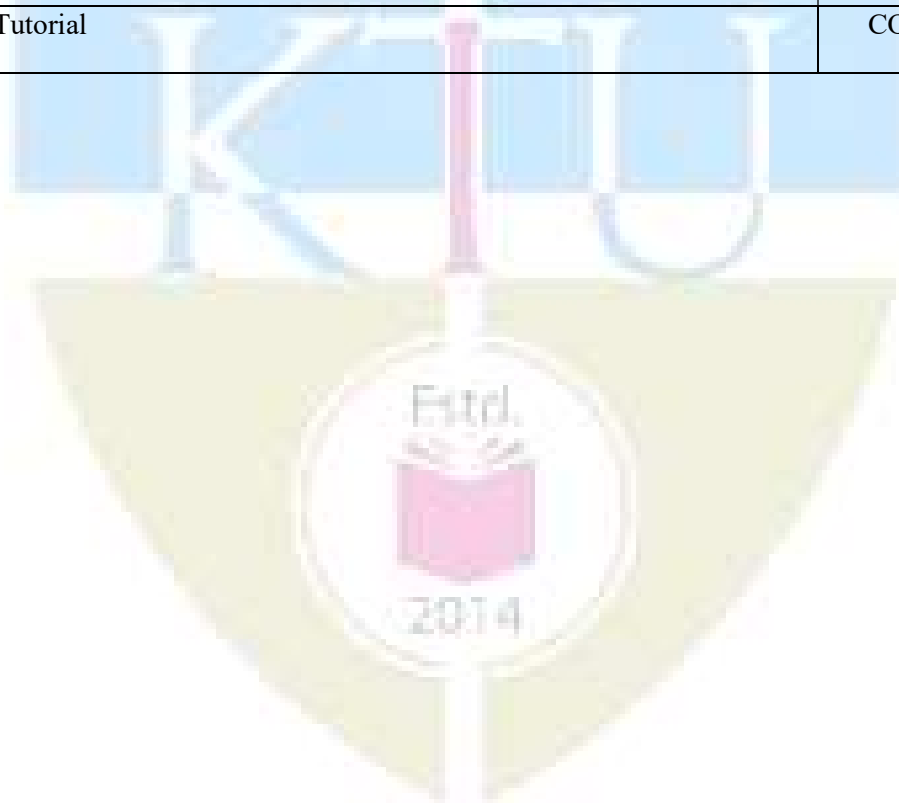

CET205	SURVEYING & GEOMATICS	CATEGORY	L	T	P	CREDIT	YEAR OF INTRODUCTION
		PCC	4	0	0	4	2019

Preamble:

Objective of the course is to impart an awareness on the principles of surveying, various methods and instruments of surveying, errors associated with field measurements and advanced surveying techniques.

Prerequisite: Nil

Course Outcomes: After the completion of the course, the student will be able to:

CO 1	Apply surveying techniques and principles of leveling for the preparation of contour maps, computation of area-volume and sketching mass diagram
CO 2	Apply the principles of surveying for triangulation
CO 3	Apply different methods of traverse surveying and traverse balancing
CO 4	Identify the possible errors in surveying and apply the corrections in field measurements
CO 5	Apply the basic knowledge of setting out of different types of curves
CO 6	Employ surveying techniques using advanced surveying equipments

Mapping of course outcomes with program outcomes

	PO 1	PO 2	PO 3	PO 4	PO 5	PO 6	PO 7	PO 8	PO 9	PO 10	PO 11	PO 12
CO 1	3	3		2	2							
CO 2	3	3		2								
CO 3	3	3						1	2			
CO 4	3	2										
CO 5	3	2	1	1				1	2			
CO 6	3			2	2			1				2

Assessment Pattern

Bloom's Category	Continuous Assessment		End Semester Examination (marks)
	Test 1 Marks	Test 2 Marks	
Remember	7.5	7.5	30
Understand	7.5	7.5	30
Apply	10	10	40
Analyse			
Evaluate			
Create			

Mark Distribution

Total Marks	CIE (Marks)	ESE (Marks)	ESE Duration
150	50	100	3 hours

Continuous Internal Evaluation Pattern:

Attendance	: 10 marks
Continuous Assessment Test (2 numbers)	: 25 marks
Assignment/Quiz/Course Project	: 15 marks

End Semester Examination Pattern:

The question consists of two parts- Part A and Part B. Part A consists of 10 questions with 3 marks for each (two questions from each module). Part B consists of two questions from each module, out of which one has to be answered. Each question carries 14 marks and can have maximum 2 subdivisions.

Sample Course Level Assessment Questions:

Course Outcome 1 (CO1): The following perpendicular offsets were taken at 10m intervals from a survey line AB to an irregular boundary line: 2.50, 3.80, 4.33, 6.76, 5.30, 7.25, 8.95, 8.25 and 5.50. Calculate the area in sqm, enclosed between the survey line, the irregular boundary, the first and the last offsets by i) Simpsons rule ii) Trapezoidal rule.

Course Outcome 2 (CO2): What is meant by satellite station and reduction to centre. From an eccentric station S, 13 metres to the west of the main station B, the following angles were measured. Angle BSC = $75^{\circ}25'32''$, Angle CSA = $55^{\circ}32'20''$. The stations S and C are to the opposite sides of the line AB. Calculate the correct angle ABC if the lengths AB and BC are 5288m and 4940m respectively

Course Outcome 3 (CO3): How do you balance a closed traverse with closing error using the graphical method of Bowditch's rule?

Course Outcome 4 (CO4): How is the most probable value in direct observations of equal weights determined?

Course Outcome 5 (CO5): How do you set out a simple curve by Rankine's method of tangential angles. Calculate the necessary data for setting out a curve of 300 m radius. Assume any other data, if required.

Course Outcome 6 (CO6): What are spectral signature curves? Discuss the spectral reflectance of soil, water and vegetation.

Syllabus

Module 1

Introduction to Surveying- Principles, Linear, angular and graphical methods, Survey stations, Survey lines- ranging, Bearing of survey lines, Local attraction, Declination, Methods of orientation (by compass and by backsighting)

Levelling: Principles of levelling- Dumpy level, booking and reducing levels, Methods- simple, differential, reciprocal leveling, profile levelling and cross sectioning. Digital and Auto Level, Errors in leveling

Contouring: Characteristics, methods, uses.

Module 2

Area and Volume: computation of area by offsets to base line, by dividing area into number of triangles; volume of level section by prismoidal and trapezoidal formulae.

Mass diagram: Construction, Characteristics and uses

Theodolite survey: Instruments, Measurement of horizontal and vertical angle, principles of stadia and tangential tacheometry (introduction only)

Triangulation: Triangulation figures, Triangulation stations, Inter visibility of stations, Satellite Stations and reduction to centre.

Module 3

Traverse Surveying - Methods of traversing, Checks in closed traverse, Traverse computations, Balancing the traverse- Bowditch's rule, Transit rule, graphical method based on Bowditch's rule, omitted measurements (a line and an angle only)

Theory of Errors – Types, theory of least squares, Weighting of observations, Most probable value, Computation of indirectly observed quantities - method of normal equations.

Module 4

Curve Surveying – Elements of simple and compound curves – Methods of setting out (Angular methods only)– Elements of Reverse curve (Introduction only)– Transition curve – length of curve – Elements of transition curve - Vertical curve (Introduction only)

Total Station – concept of EDM, principles and working, advantages and applications

Module 5

Global Positioning Systems-Components and principles, satellite ranging-calculating position, signal structure, application of GPS, GPS Surveying methods-Static, Rapid static, Kinematic methods – DGPS

Remote Sensing : Definition- Electromagnetic spectrum-Energy interactions with atmosphere and earth surface features-spectral reflectance of vegetation, soil and water- Classification of sensors- Active and Passive, Resolution-spatial, spectral radiometric and Temporal resolution, Multi spectral scanning-Along track and across track scanning

Geographical Information System-components of GIS, GIS operations, Map projections-methods, Coordinate systems-Geographic and Projected coordinate systems, Data Types- Spatial and attribute data, Raster and vector data representation

Text Books :

1. Dr. B.C. Punmia , Ashok Kumar Jain & Arun Kumar Jain - Surveying , Laxmi publications (P) Ltd , 2005
2. Chang, K , “Introduction to Geographic Information Systems”, Tata McGraw-Hill Publishing Co. Ltd, 2008
3. George Joseph, “Fundamentals of Remote Sensing”, University Press, 2003

References :

1. C. Venkatramaiah, Textbook of Surveying, Universities Press (India) Private Limited 2011
2. James M Andersen, Edward M Mikhail, Surveying Theory and Practice, McGraw Hill Education
4. Prof. T.P. Kenetkar & Prof. S.V. Kulkarni - Surveying and Levelling , Pune Vidyarthi Griha Prakashan, 2004
5. N N Basak, Surveying and Levelling, McGraw Hill Education
6. R. Agor - A Text book of Surveying and Levelling, Khanna Publishers, 2005
3. S.K. Duggal - Surveying Vol. I, Tata McGraw Hill Ltd , Reprint 2015.
7. S.K. Duggal - Surveying Vol. II, Tata McGraw Hill Ltd , Reprint 2015
4. Burrough P , Principles of Geographical Information systems, Oxford University Press, 1998
5. Iliffe, C.J., Datums and Map Projections for Remote Sensing, GIS and Surveying, Whittles Publishing, 2006
6. James M Andersen, Edward M Mikhail, Surveying Theory and Practice, McGraw Hill education, 7e, 1998
7. Kang-tsung Chang, „Introduction to GIS“ , Tata McGraw-Hill Publishing Co. Ltd, 8e, 2016
8. Lillesand M and Kiefer W, “Remote Sensing and Image Interpretation”. John Wiley and Sons, Inc., 2000

Course Content and lecture Schedule:

No.	Topic	Course Outcome	No. of Hrs
1	Module 1		Total: 9
1.1	Introduction to Surveying- Principles, Linear, angular and graphical methods, Survey stations, Survey lines- ranging, Bearing of survey lines, Local attraction, Declination, Methods of orientation	CO1	4
1.2	Levelling: Principles of levelling- Dumpy level, booking and reducing levels, Methods- simple, differential, reciprocal leveling, profile levelling and cross sectioning. Digital and Auto Level, Errors in leveling	CO1	4
1.3	Contouring: Characteristics, methods, uses.	CO1	1
2	Module 2		Total: 9
2.1	Area and Volume: computation of area by offsets to base line, by dividing area into number of triangles; volume of level section by prismoidal and trapezoidal formulae.	CO1	3
2.2	Mass diagram: Construction, Characteristics and uses	CO1	1
2.3	Theodolite survey: Instruments, Measurement of horizontal and vertical angle, principles of stadia and tangential tacheometry (introduction only)	CO2	2
2.4	Triangulation: Triangulation figures, Triangulation stations, Inter visibility of stations, Satellite Stations and reduction to centre.	CO2	3
3	Module 3		Total: 9
3.1	Traverse Surveying - Methods of traversing, Checks in closed traverse, Traverse computations, Balancing the traverse- Bowditch's rule, Transit rule, graphical method based on Bowditch's rule, Gales Traverse table, omitted measurements (a line and an angle only)	CO3	5
3.2	Theory of Errors – Types, theory of least squares, Weighting of observations, Most probable value, Computation of indirectly observed quantities - method of normal equations.	CO4	4
4	Module 4		Total: 9
4.1	Curve Surveying – Elements of simple and compound curves – Methods of setting out (Angular methods only)– Elements of Reverse curve (Introduction only)– Transition curve – length of curve – Elements of transition curve - Vertical curve (introduction only)	CO5	6
4.2	Total Station – concept of EDM, principles and working, advantages and applications	CO6	3
5	Module 5		Total: 9
5.1	Global Positioning Systems- Components and Principles, Satellite ranging-calculating position, signal structure,	CO6	3

	application of GPS, GPS Surveying methods-Static, Rapid static , Kinematic methods – DGPS		
5.2	Remote Sensing : Definition- Electromagnetic spectrum- Energy interactions with atmosphere and earth surface features- spectral reflectance of vegetation, soil and water- Classification of sensors- Active and Passive, Resolution-spatial, spectral radiometric and Temporal resolution, Multi spectral scanning- Along track and across track scanning	CO6	3
5.3	Geographical Information System -components of GIS, GIS operations, Map projections- methods, Coordinate systems- Geographic and Projected coordinate systems, Data Types- Spatial and attribute data, Raster and vector data representation	CO6	3

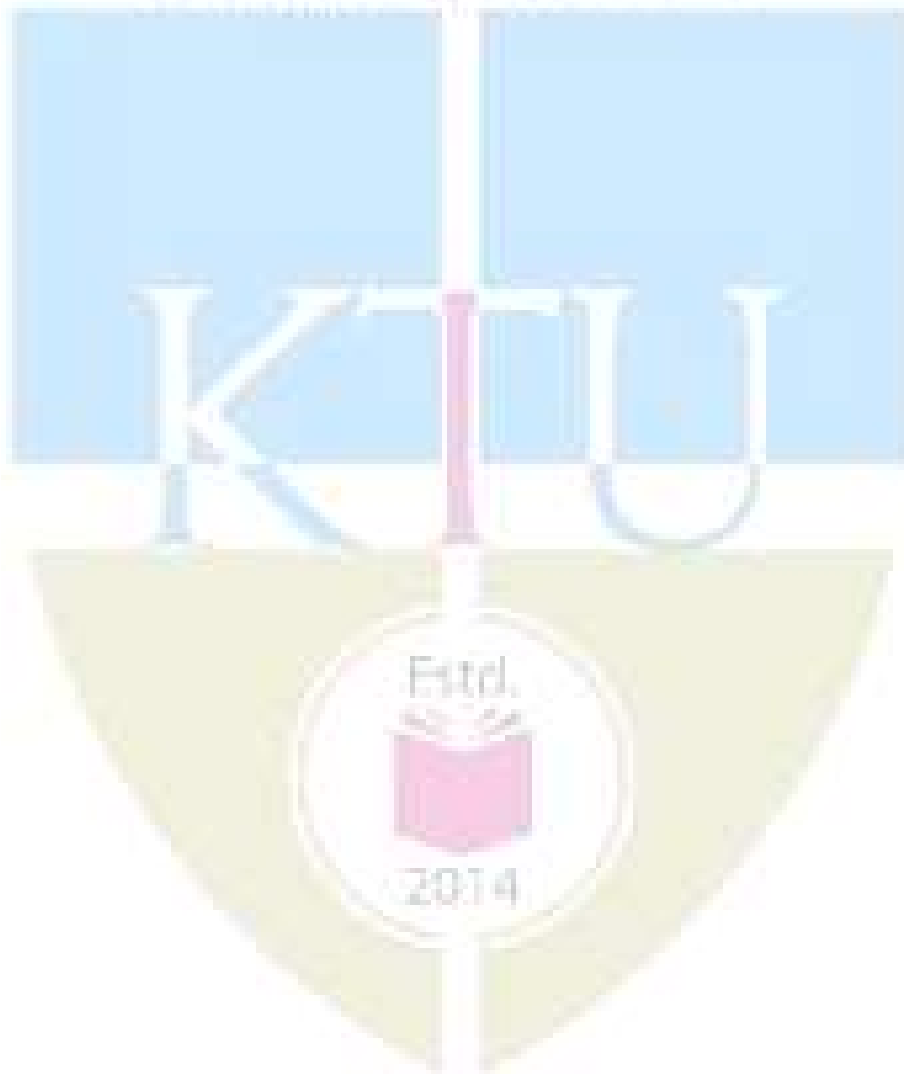

**APJ ABDUL KALAM TECHNOLOGICAL UNIVERSITY
THIRD SEMESTER B. TECH DEGREE EXAMINATION, MONTH & YEAR**

Course Code: **CET 205**

Course Name: **SURVEYING & GEOMATICS**
Model Question Paper

Marks: 100

Duration: 3 hrs

PART A

(Answer all Questions: Each question carries 3 marks)

1. What are the general principles of surveying?
2. Define back sight, foresight and intermediate sight.
3. How do you determine the intervisibility of triangulation stations?
4. What is the principle of stadia tacheometry?
5. How will you determine probable error of computed quantities?
6. What are the checks in closed traverse?
7. What are the elements of a compound curve?
8. Explain the two theodolite method of setting out of simple curve.
9. What is multi spectral scanning? Differentiate along track and across track scanning.
10. What is meant by satellite ranging?

PART B

(Answer one full question from each module)

11. a. Define contour. What are the characteristics of contour? (4)

- b. The following readings were taken in a running closed compass traverse.
 Line FB BB
 AB $49^{\circ}55' 230^{\circ}00'$
 BC $177^{\circ}45' 356^{\circ}00'$
 CD $104^{\circ}15' 284^{\circ}55'$
 DE $165^{\circ}15' 345^{\circ}15'$
 EA $259^{\circ}30' 79^{\circ}90'$
 - i) State the stations which were affected by local attraction.
 - ii) Determine the corrected bearings
 - iii) Calculate the true bearings if the declination was $1^{\circ} 30' W$. (10)

OR

12. a. What are the different methods of orientation in plane table surveying? (4)

- b. The following readings were taken with a dumpy level and a 4 m levelling staff on a continuously sloping ground at 30m intervals. 0.685, 1.455, 1.850, 2.330, 2.885, 3.380, 1.055, 1.860, 2.265, 3.540, 0.835, 0.945, 1.530 and 2.250. The reduced level of the first point is 80.750. Rule out a page of a level book and enter the above readings. Determine RLs of all points using height of instrument method. Determine the gradient of the line joining the first and last point. (10)
13. a. The following perpendicular offsets were taken at 10m intervals from a survey line AB to an irregular boundary line: 2.50, 3.80, 4.33, 6.76, 5.30, 7.25, 8.95, 8.25 and 5.50. Calculate the area in sqm, enclosed between the survey line, the irregular boundary, the first and the last offsets by i) Simpsons rule ii) Trapezoidal rule. (10)
- b. Explain Mass diagram and its characteristics features. (4)

OR

14. a. Explain the method of observing the horizontal angle by the method of repetition and reiteration in triangulation survey. (4)
- b. What is meant by satellite station and reduction to centre. From an eccentric station S, 13 metres to the west of the main station B, the following angles were measured. Angle BSC = $75^{\circ}25'32''$, Angle CSA = $55^{\circ}32'20''$. The stations S and C are to the opposite sides of the line AB. Calculate the correct angle ABC if the lengths AB and BC are 5288m and 4940m respectively. (10)
15. a. The following are the mean values observed in the measurement of three angles A, B, C at one station
 A = $86^{\circ}42'46.2''$ with weight 4
 A+B = $134^{\circ}36'33.6''$ with weight 3
 A+B+C = $262^{\circ}18'10.4''$ with weight 1
 B+C = $185^{\circ}35'24.8''$ with weight 2
 Calculate the most probable value of A, B and C. (10)
- b. Distinguish between a) closed traverse and open traverse b) loose needle method and fast needle method of traverse surveying (4)

OR

16. a. State the fundamental principle of method of least squares. How is the most probable value in direct observations of equal weights determined? (7)
- b. Describe the procedures for balancing a closed traverse by graphical method. (7)
17. a. Two tangents intersect at chainage 1000 m, the deflection angle being $60^{\circ}20'$. Calculate the necessary data for setting out a curve of 200 m radius to connect two tangents if it is intended to set out the curve by Rankine's method of tangential angles. Take peg interval equal to 20 m. (10)

b. What are the advantages and applications of Total Station survey?(4)

OR

18. a. What is transition curve? What are its functions? What are the methods to find out the length of transition curve? (10)

19. b. Explain the principle behind electro magnetic distance measurement. (4)

20. a. What are the components of GPS? Illustrate with figure. Explain the functions of each of them in detail. (10)

b. What are the applications of GIS? (4)

OR

21. a. How does electro magnetic radiation interact with atmosphere? (7)

b. What are the various types of map projections based on the projection surface? (7)

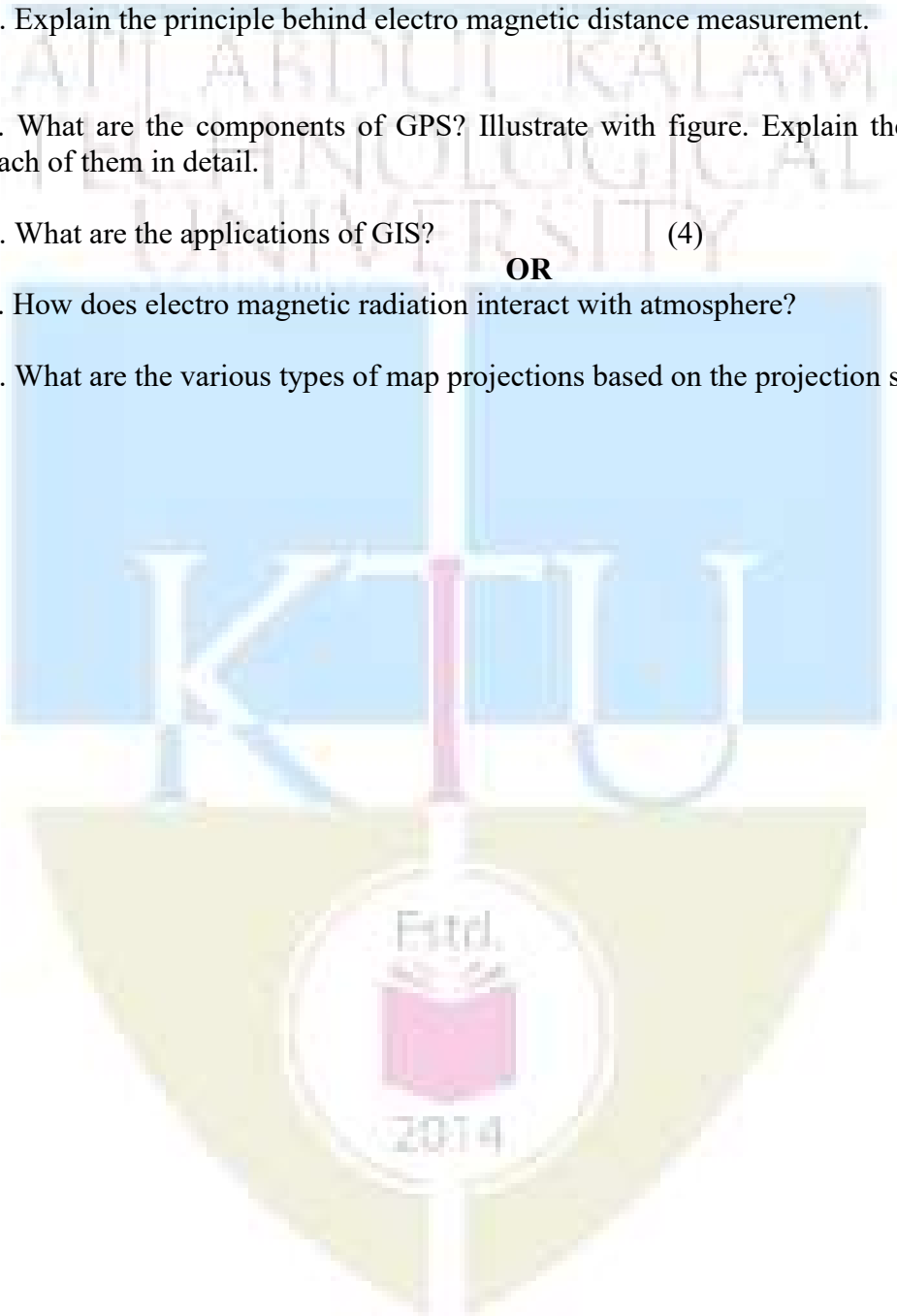

CEL 201	CIVIL ENGINEERING PLANNING & DRAFTING LAB	CATEGORY	L	T	P	CREDIT	YEAR OF INTRODUCTION
		PCC	0	0	3	2	2019

Preamble: The course is designed to introduce the fundamentals of Civil Engineering drawing and understand the principles of planning. The students will be able to learn the drafting of buildings manually and using drafting software such as AutoCAD.

Prerequisite: ENGINEERING GRAPHICS

Course Outcomes and their assessment: After the completion of the course, the student will be able to:

Course Outcome (CO)	Course Outcome Description	CO assessment strategy
CO 1	Illustrate ability to organise civil engineering drawings systematically and professionally	Assessment of the overall organisation of the drawing, labels and templates used.
CO 2	Prepare building drawings as per the specified guidelines.	Application of guidelines for functional planning of building unit.
CO 3	Assess a complete building drawing to include all necessary information	Level of incorporation of Guidelines specified by NBC, meeting the requirement of building rules specified by local bodies of administration.
CO 4	Create a digital form of the building plan using any drafting software	Evaluation of the printouts of prepared building plan

Mapping of course outcomes (COs) with program outcomes (POs)

CO/PO	PO 1	PO 2	PO 3	PO 4	PO 5	PO 6	PO 7	PO 8	PO 9	PO 10	PO 11	PO 12
CO 1	3	-	-	-	-	-	-	2	3	3	-	-
CO 2	3	-	-	-	-	-	-	2	3	3	-	-
CO 3	3	-	-	-	-	-	-	2	3	3	-	-
CO 4	3	-	-	-	-	-	-	2	2	3	-	-

List of Experiments (Any 12 experiments out of 15 need to be performed mandatorily. Manual drafting and drafting using computer aided drafting software is mandatory for the experiments)

1. Draw sectional details and elevation of paneled doors
2. Draw sectional details and elevation of glazed windows and ventilators in wood.
3. Draw sectional details , detailing on fixing arrangement and elevation of steel windows.
4. Draw elevation, section and detailing of connection between members, arrangement for fixing at the support for steel roof truss.
5. Draw plan, section and elevation of dog legged staircase.
6. Draw sectional details of a load bearing wall over strip footing, RCC Column over isolated footing and pile footing with pile cap.
7. Draw plan, section and elevation of single storied residential buildings with flat roof.
8. Draw plan, section and elevation of two storied residential building.
9. Draw plan , section and elevation of a community hall having corrugated GI sheet roof.
10. Prepare a site plan and service plan as per latest building rules (KPBR or KMBR)
11. Prepare detailed drawing on building services (for single and two storied buildings only) and on-site wastewater disposal systems like septic tank and soak pit.
12. Draw plan, section and elevation of multi-storied framed buildings.
13. Draw plan, section and elevation of a public buildings—office complex, public health centre, post office, bank etc
14. Draw plan, section and elevation of a industrial building with corrugated GI steel roof and PEB based walling elements.
15. Create 3D model of a two storied residential building and render the model.

References

- 1.** National Building Code of India
- 2.** Kerala panchayat building rules, 2019
- 3.** Kerala Municipality building rules, 2019
- 4.** Dr. Balagopal T.S. Prabhu, Building Drawing and Detailing, Spades Publishers, Calicut
- 5.** AutoCAD Essentials, Autodesk official Press, John Wiley & Sons, USA
- 6.** Shah, M.G., Kale, C. M. and Patki, S.Y. Building Drawing With An Intergrated Approach to Built Environment, Tata McGraw Hill Publishing Company Limited, New Delhi

Mark distribution

Total Marks	CIE	ESE	ESE Duration
150	75	75	2.5 hours

Continuous Internal Evaluation Pattern:

Marks for 12 exercises using manual drafting in A4 Paper : **50 marks**

Marks for 12 exercises using computer aided drafting software in A3/A4 paper: **25 marks**

COs	Assessment Strategy	Marking Criteria	Marks
CO 1	Assessment of the overall organisation of the drawing, labels and templates used.	Marks to be awarded based on the initial preparations displayed in manual drawing	10
CO 2	Application of guidelines for functional planning of building unit.	Marks to be awarded based on the prepared plan of the building	20
CO 3	Level of incorporation of Guidelines specified by NBC, meeting the requirement of building rules specified by local bodies of administration.	Marks to be awarded based on the checklists of assessment for the prepared plan of the building	20
CO 4	Evaluation of the printouts of prepared building plan	Marks to be awarded based on the printout of the final plan of the building	25

End Semester Examination Pattern: ESE will be of **2.5 hours** duration on A2 size answer booklet and will be for 75 marks. (only manual drafting for ESE)



CEL 203	SURVEY LAB	CATEGORY	L	T	P	CREDIT
		PCC	0	0	3	2

Preamble:

Objective of the course is to impart practical experience to students by exposing them to various techniques of field surveying. The course is designed to make student familiar with conventional and advanced surveying instruments.

Prerequisite: Nil

Course Outcomes: After the completion of the course, the student will be able to:

CO 1	Use conventional surveying tools such as chain/tape and compass for plotting and area determination.
CO 2	Apply levelling principles in field
CO 3	Solve triangulation problems using theodolite
CO 4	Employ total station for field surveying
CO 5	Demonstrate the use of distomat and handheld GPS

Mapping of course outcomes with program outcomes

	PO 1	PO 2	PO 3	PO 4	PO 5	PO 6	PO 7	PO 8	PO 9	PO 10	PO 11	PO 12
CO 1	3							1	2			
CO 2	3			1				1	2			
CO 3	3			1				1	2			
CO 4	3			1	3			1	2			2
CO 5	3				3			1				2

Course Level Assessment Questions

Course Outcome 1 (CO1): Plot the given area using chain/tape and compass and compute its area.

Course Outcome 2 (CO2): Determine the reduced levels of the given points in the field with respect to the Bench Mark of RL=100.00

Course Outcome 3 (CO3): Find out the distance between two inaccessible points A and B. Baseline measurement is allowed.

Course Outcome 4 (CO4): Compute the area of a given plot using total station.

Course Outcome 5 (CO5): Explain the parts of a handheld GPS with neat sketch.

Assessment Pattern

Bloom's Category	Continuous Assessment	End Semester Examination (marks)
Remember	10	15
Understand	10	15
Apply	40	40
Analyse		
Evaluate		
Create		

Mark Distribution

Total Marks	CIE (Marks)	ESE (Marks)	ESE Duration
150	75	75	2.5 hours

Continuous Internal Evaluation (CIE) Pattern

Attendance	:	15 marks
Continuous Assessment	:	30 marks
Internal Test (Immediately before the second series test)	:	30 marks

End Semester Examination (ESE) Pattern:

Practical examination shall include problems on leveling/theodolite and total station with equal mark distribution. The following guidelines should be followed regarding award of marks

- | | | |
|--|---|----------|
| (a) Preliminary work | : | 15 Marks |
| (b) Implementing the work/Conducting the experiment | : | 10 Marks |
| (c) Performance, result and inference (usage of equipments and trouble shooting) | : | 25 Marks |
| (d) Viva voce | : | 20 marks |
| (e) Record | : | 5 Marks |

General instructions:

Practical examination to be conducted immediately after the second series test covering entire syllabus given below. Evaluation is a serious process that is to be conducted under the equal responsibility of both the internal and external examiners. The number of candidates evaluated per day should not exceed 20. Students shall be allowed for the University examination only on submitting the duly certified record. The external examiner shall endorse the record.

Syllabus

List of Exercises/ Experiments:

1. Introduction to conventional surveying - 1 session
2. Levelling - 4sessions
3. Theodolite surveying - 5sessions
4. Total Station survey - 4sessions
5. Study of instruments - 1 session
 - Automatic level
 - digital level
 - Handheld GPS

Course Content and Practical Schedule (Any twelve experiments are mandatory):

Expt. No.	List of exercises/experiments	Course Outcome	No. of Hrs
1	Introduction to conventional surveying a. Chain surveying b. Compass surveying	CO1	3
2	Levelling Simple leveling	CO2	3
3	Differential levelling		3
4	Fly levelling		3
5	Contouring		3
6	Theodolite surveying Distance between accessible points (horizontal angle)		CO3
7	Distance between inaccessible points (horizontal angle)	3	
8	Level difference between points (vertical angle)	3	
9	Tangential tacheometry (vertical angle)	3	
10	Height of building (vertical angle)	3	
11	Total station survey Heights and distances	CO4	3
12	Area computation		3
13	Contouring		3
14	Downloading		3
15	Study of instruments a. Automatic level b. Digital level c. Handheld GPS	CO5	3

Reference Books

1. Dr. B.C. Punmia , Ashok Kumar Jain & Arun Kumar Jain - Surveying , Laxmi publications (P) Ltd , 2005
2. C. Venkatramaiah, Textbook of Surveying, Universities Press (India) Private Limited 2011

3. Prof. T.P.Kenetkar&Prof.S.V.Kulkarni - Surveying and Levelling , Pune VidyarthiGriha Prakashan,2004
4. R.Agor - A Text book of Surveying and Levelling, Khanna Publishers, 2005
5. S.K.Duggal - Surveying Vol. I, Tata McGraw Hill Ltd ,Reprint 2015.
6. S.K. Duggal - Surveying Vol. II, Tata McGraw Hill Ltd ,Reprint 2015



ABDUL KALAM
TECHNOLOGICAL
UNIVERSITY

SEMESTER -3
MINOR



CET281	BUILDING CONSTRUCTION AND STRUCTURAL SYSTEMS	CATEGORY	L	T	P	CREDIT	Year of Introduction
		VAC	4	0	0	4	2019

Preamble:

This course provides the essential aspects of building construction such as components of buildings, materials of construction and structural systems to the students of other branches of Engineering.

Pre requisite: Nil

Course Outcomes: After the completion of the course the student will be able to

Course Outcome	Description of Course Outcome	Prescribed learning level
CO1	Explain the properties and testing methods of different materials used for building construction.	Understanding
CO2	Explain the construction details of different components of buildings.	Understanding
CO3	Explain construction practices such as prefabricated, cost effective and sustainable technologies	Understanding
CO4	Explain the details and behavior of structural systems and structural elements used in buildings.	Understanding

Mapping of course outcomes with program outcomes (Minimum requirement)

	PO1	PO2	PO3	PO4	PO5	PO6	PO7	PO8	PO9	PO10	PO11	PO12
CO1	2		-	-	-	-	-	-	-	-	-	-
CO2	2		-	-	-	-	-	-	-	-	-	-
CO3	2		-	-	-	-	-	-	-	-	-	-
CO4	2		-	-	-	-	-	-	-	-	-	-

Mark distribution

Total Marks	CIE	ESE	ESE Duration
150	50	100	3 hours

Continuous Internal Evaluation Pattern:

Attendance	: 10 marks
Continuous Assessment Test (2 numbers)	: 25 marks
Assignment/Quiz/Course project	: 15 marks

End Semester Examination Pattern: There will be two parts; Part A and Part B. Part A contain 10 questions with 2 questions from each module, having 3 marks for each question. Students should answer all questions. Part B contains 2 questions from each module of which student should answer any one. Each question carries 14 marks and can have maximum 2 sub-divisions.

Course Level Assessment Questions

CO1 Explain the properties and testing methods of different materials used for building construction.

1. What is blended cement? What are its advantages?
2. Explain any one test performed on coarse aggregate.
3. Discuss the role of admixtures in concrete
4. Explain any one test performed in fresh concrete.
5. Explain any one test performed on hardened concrete.

CO2 Explain the construction details of different components of buildings.

1. What is a lintel? Why is it required?
2. Explain the different types of shallow foundations.
3. Explain the different types of deep foundations.
4. Explain the procedure adopted for laying marble flooring.

CO3 Explain construction practices such as prefabricated, cost effective and sustainable technologies

1. What is prefabrication? What are the advantages and disadvantages of prefabricated construction?
2. Explain the construction details of rat-trap bond masonry.
3. Explain the principles of filler slab.

CO4 Explain the details and behavior of structural systems and structural elements used in buildings.

1. What are the different forms of reinforcement used in columns? Explain the functions of each.
2. Distinguish between load bearing wall construction and moment resisting frame construction.
3. Sketch any two types of steel roof truss.
4. Sketch the reinforcement details of a simply supported beam.

SYLLABUS

Module -1

Cement – Types, Composition, manufacturing process, properties, tests. Aggregates – properties, tests. Mortar – types, properties, uses. Chemical admixtures – types, uses.

Module -2

Concrete – PCC, RCC. Properties of fresh concrete, Workability – tests. Properties of hardened concrete – tests for strength, Nominal mix and design mix.

Module -3

Flooring and roofing materials, Lintels and arches, Types and construction details of doors, windows and ventilators. Finishing works, Timber products, Formwork

Module -4

Foundations – shallow and deep, Cost effective construction, Sustainable building technologies, Non destructive testing of concrete, Prefabricated construction.

Module -5

Structural elements - beams, columns and slabs. Principles of reinforced concrete, types of reinforcements, Reinforcement details of structural elements, Structural systems, Concrete floor systems.

Text Books

1. Punmia B. C, Building Construction, Laxmi Publications
2. Arora and Bindra, Building Construction, Dhanpath Rai and Sons.
3. Shetty M.S., Concrete Technology, S. Chand & company.

References

1. Madan Mehta, Walter Scarborough and Diane Armpriest, Building Construction – Principles, Materials and Systems, Pearson.
2. Daniel Schodek and Martin Bechthold, Structures, Pearson.
3. V. SankaraSubramaniyan, Construction Technology, Lakshmi Publications, Chennai.
4. S. S. Bhavikatti, Construction Technology, Chess Educational Publishers, Chennai.
5. Rangwala S C., Engineering Materials, Charotar Publishers.

6. P. C. Varghese, Building Materials, PHI Learning Pvt Ltd., Delhi.
7. Mehta and Monteiro, Concrete - Micro structure, Properties and Materials, McGraw Hill Professional.
8. Neville A. M. and Brooks J. J., Concrete Technology, Pearson Education.
9. R. Santhakumar, Concrete Technology, Oxford Publications.

Lecture Plan - Building Construction and Structural Systems

<i>Module</i>	<i>Topic</i>	<i>Course Outcomes addressed</i>	<i>No. of Lectures</i>
1	Module I : Total lecture hours : 9		
1.1	Cement – Types of cements, chemical composition. Blended cements	CO1	1
1.2	Manufacturing of cement	CO1	1
1.3	Properties and tests on cement, Hydration of cement	CO1	2
1.4	Aggregates – types, role of aggregates.	CO1	1
1.5	Properties of aggregates and tests. Grading requirements. Natural and synthetic aggregates	CO1	2
1.6	Mortar – types, Sand – properties, uses	CO1	1
1.7	Water quality for construction. Chemical admixtures – types and uses.	CO1	1
2	Module II : Total lecture hours : 10		
2.1	Concrete – PCC, RCC and Prestressed concrete (brief descriptions only)	CO1	1
2.2	Making of concrete – batching, mixing, transporting, placing, compacting, finishing and curing	CO1	2
2.3	Properties of fresh concrete – workability, segregation and bleeding.	CO1	1
2.4	Factors affecting workability and strength – tests on workability, demonstration of slump test.	CO1	2
2.5	Effects of aggregates on properties of concrete	CO1	1
2.6	Properties of hardened concrete – tests for strength of concrete in compression, tension and flexure.	CO1	2
2.7	Nominal mixes and design mixes, mix designations, ready mixed concrete	CO1	1
3	Module III : Total lecture hours : 8		
3.1	Flooring and roofing materials	CO2	1
3.2	Lintels and arches – types.	CO2	1
3.3	Doors, Windows and ventilators – types and construction	CO2	2

	details		
3.4	Finishing works. Paint – types	CO1	1
3.5	Timber – seasoning	CO1	1
3.6	Timber products – properties and uses of plywood, fibre board and particle board	CO1	1
3.7	Formwork, Construction and expansion joints	CO2	1
4	Module IV : Total lecture hours : 10		
4.1	Types of shallow foundations.	CO2	1
4.2	Types of deep foundations.	CO2	1
4.3	Foundation failure – causes	CO2	1
4.4	Introduction to cost effective construction – principles of filler slab and rat-trap bond masonry.	CO3	2
4.5	Sustainable building technologies.	CO3	2
4.6	Non destructive testing of concrete – rebound hammer test and ultrasonic pulse velocity test.(with demonstrations)	CO1	2
4.7	Introduction to prefabricated construction- advantages, slip form construction	CO3	1
5	Module V : Total lecture hours : 8		
5.1	Introduction to structural systems – functions, Primary structural elements – beams, columns and slabs.	CO4	1
5.2	Principles of reinforced concrete, types of reinforcements – tension reinforcements, compression reinforcements and stirrups.	CO4	2
5.3	Reinforcement details of beams, columns and slabs.	CO4	2
5.4	Structural systems – load bearing walls, moment resisting frames	CO4	1
5.5	Structural systems – trusses, cables and membranes	CO4	1
5.6	Elevated concrete floor systems, beams supported concrete floors – one way and two way slabs, flat slabs.	CO4	1

MODEL QUESTION PAPER

Reg.No.: _____

Name: _____

APJ ABDUL KALAM TECHNOLOGICAL UNIVERSITY
THIRD SEMESTER B.TECH DEGREE EXAMINATION

Course Code: CET281

Course Name: BUILDING CONSTRUCTION AND STRUCTURAL SYSTEMS

Max. Marks: 100

Duration: 3 Hours

PART A

Answer all questions; each question carries 3 marks.

1. a) What is hydration of cement?
- b) What is mortar? What are its uses?
- c) What are the advantages of prestressed concrete over conventional reinforced concrete?
- d) Distinguish between nominal mix and design mix.
- e) Name different types of paints and mention their use.
- f) List different types of timber products used in building construction.
- g) What is a raft foundation?
- h) Explain any one non destructive test used to assess the quality of concrete.
- i) What is a truss? How does a truss resist external loads?
- j) Why is reinforcement essential in concrete beams?

(10×3 marks = 30 marks)

PART B

Answer one full question from each module; each full question carries 14 marks.

Module I

2. a) What is mean by grading of aggregates? (5)
- b) Explain the process of manufacturing cement. (9)
3. a) Explain the role of admixtures in concrete (5)
- b) Explain the various tests used to assess properties of cement. (9)

Module II

4. a) What is curing of concrete? Why is it important? (5)
- b) What is meant by workability of concrete? Discuss the factors influencing workability of concrete. (9)
5. a) Distinguish between segregation and bleeding. (5)

- b) Explain the various tests performed on hardened concrete. (9)

Module III

6. a) Sketch a typical arch and mark its parts. (5)
 b) What is seasoning of timber? Explain different methods of seasoning. (9)
7. a) What is a lintel? Why it is required? (5)
 b) Explain different types of scaffoldings. (9)

Module IV

8. a) Explain with neat sketches any three types of foundations. (6)
 b) Describe the causes of foundation failure. (8)
9. a) What is a slip form? Where are they used? (6)
 b) Explain the construction of filler slabs. (8)

Module V

10. a) What are the functions of a structural system? (5)
 b) With the help of neat sketches, explain the different forms of reinforcement used in beams? Also explain the functions of each. (9)
11. a) Distinguish between one way and two way slab systems. (5)
 b) Compare load bearing wall construction and moment resisting frame construction. (9)

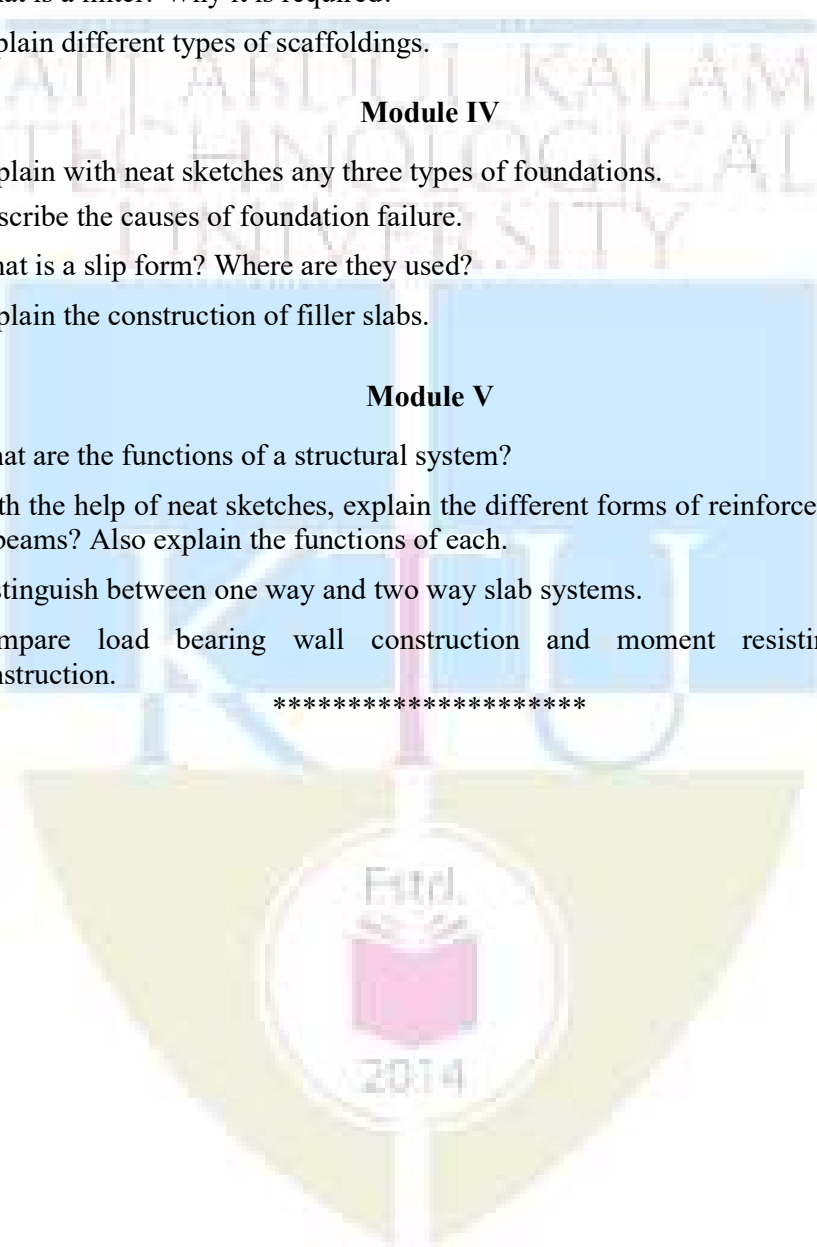

CET 283	INTRODUCTION TO GEOTECHNICAL ENGINEERING	CATEGORY	L	T	P	CREDIT	Year of Introduction
		VAC	4	0	0	4	2019

Preamble: Goal of this course is to expose the students to the fundamental concepts of soil mechanics and foundation engineering. After this course, students will be able to identify and classify the soil and to recognize practical problems in real-world situations and respond accordingly.

Prerequisite : Nil

Course Outcomes: After completion of the course the student will be able to:

CO 1	Explain the basic concepts, theories and methods of analysis in soil mechanics and foundation engineering
CO 2	Solve the basic properties of soil by applying functional relationships
CO 3	Determine the engineering properties of soil by applying the laboratory test results and the fundamental concepts
CO 4	Estimate the design parameters of footings and retaining walls

Mapping of course outcomes with program outcomes (Minimum requirement)

	PO 1	PO 2	PO 3	PO 4	PO 5	PO 6	PO 7	PO 8	PO 9	PO 10	PO 11	PO 12
CO 1	3	-	-	-	-	-	-	-	-	-	-	-
CO 2	2	3	-	-	-	-	-	-	-	-	-	-
CO 3	2	3	-	-	-	-	-	-	-	-	-	-
CO 4	2	3	-	-	-	-	-	-	-	-	-	-

Assessment Pattern

Bloom's Category	Continuous Assessment Tests		End Semester Examination (Marks)
	Test 1 (Marks)	Test 2 (Marks)	
Remember	15	15	30
Understand	10	10	20
Apply	25	25	50
Analyse			
Evaluate			
Create			

Mark Distribution

Total Marks	CIE Marks	ESE Marks	ESE Duration
150	50	100	3 hours

Continuous Internal Evaluation (CIE) Pattern :

Attendance	: 10 Marks
Continuous Assessment Test (2 numbers)	: 25 Marks
Assignment/Quiz/Course project	: 15 Marks

End Semester Examination (ESE) Pattern : There will be two parts; Part A and Part B. Part A contains 10 questions with 2 questions from each module, having 3 marks for each question. Students should answer all questions. Part B contains 2 questions from each module of which student should answer any one. Each question can have maximum 2 sub-divisions and carry 14 marks.

Course Level Assessment Questions

(Questions may be framed based on the outline given under each course outcome)

Course Outcome 1 (CO1):

1. The fundamental concepts of basic properties and index properties of soil
2. The fundamental concepts of engineering properties of soils related to Permeability, shear strength, consolidation & compaction
3. Concepts of Total, neutral and effective stress; and vertical stress below loaded areas
4. Basic theories of Earth pressure, Bearing Capacity and Settlement of footings

Course Outcome 2 (CO2):

1. Solve the basic properties of soil by applying functional relationships

Course Outcome 3 (CO3):

1. Calculate the engineering properties of soil related to Permeability, consolidation, compaction & shear strength by applying the laboratory test results
2. Calculate the engineering properties of soil by applying the concepts of soil mechanics related to total, neutral and effective stress; and vertical stress below loaded areas

Course Outcome 4 (CO4):

1. Estimate the earth pressure acting on the retaining walls
2. Estimate the bearing capacity of footings
3. Estimate the immediate and consolidation settlement of footings

Model Question Paper

QP CODE:

Reg No.: _____

Name: _____

APJ ABDUL KALAM TECHNOLOGICAL UNIVERSITY

FOURTH SEMESTER B.TECH DEGREE EXAMINATION, MONTH & YEAR

Course Code: CET 283

Course Name : INTRODUCTION TO GEOTECHNICAL ENGINEERING

Max. Marks: 100

Duration: 3 hours

Part A

(Answer all questions; each question carries 3 marks)

1. Draw a three phase block diagram and define (i) Void Ratio, (ii) Water Content and (iii) Degree of saturation
2. Explain different types of soil structures.
3. Define (i) Well graded, (ii) Poorly graded and (iii) Gap graded soils
4. Define (i) Liquid Limit, (ii) Plastic Limit and (iii) Shrinkage Limit
5. Explain Mohr Coulomb shear strength theory.
6. Explain different types of earth pressures.
7. Explain the situations in which combined footings are provided.
8. List the assumptions of Terzaghi's theory of bearing capacity.
9. Define (i) pre consolidation pressure, (ii) Compression Index and (iii) Recompression Index.
10. Differentiate between Consolidation and Compaction.

PART B

(Answer one full question from each module, each question carries 14 marks)

Module – 1

11. (a) Derive the relation between bulk unit weight, specific gravity, void ratio and degree of saturation from the fundamentals. (5 Marks)
- (b) A sample of wet silty clay soil weighs 1.26 kN. The following data were found from lab tests on the sample. Density $\gamma = 21$ kN/m³, Water content $w = 15\%$, Specific Gravity $G = 2.7$. Determine (i) Dry density, (ii) Void Ratio, (iii) Porosity (iv) Degree of Saturation, (v) Saturated unit weight (vi) Submerged unit weight and (vii) Volume of soil. (9 Marks)
12. (a) Explain the procedures to determine the field density of soil. (5 Marks)
- (b) 1000 cm³ core cutter weighing 9.46 N was used to find out the in-situ unit weight of soil in an embankment. The weight of core cutter with in-situ soil was noted to be 27.7 N. Laboratory tests on the sample indicated water content of 10% and specific gravity of solids of 2.63. Determine the bulk unit weight, dry unit weight, void ratio and degree of saturation. Also

calculate the saturated unit weight and the corresponding water content if the embankment is saturated during rain without change in volume. (9 Marks)

Module – 2

13. (a) Explain the factors affecting permeability of soil. (5 Marks)
 (b) A soil sample of height 6 cm and area of cross section 100 cm^2 was subjected to constant head permeability test with head of 36 cm and 90 cc of water passes through the specimen during a test interval of 5 min. Compute the coefficient of permeability of the soil sample.
 If the same sample is subjected to falling head permeability test and found that head drops from 60 cm to 20 cm in 4 min. Determine the cross sectional area of the stand pipe. (9 Marks)
14. (a) A concentrated load of 500 kN is applied at ground surface. Compute the vertical pressure (i) at a depth of 5m below the load, (ii) at a distance of 3m at the same depth. Use Boussinesq's theory. (5 Marks)
 (b) A sand deposit of 8 m thick was loaded with a uniform surcharge of 10 kN/m^2 . Water table (WT) is at 3 m below GL. Density of sand is 18 kN/m^3 above WT and 19 kN/m^3 below WT. Draw Total, Neutral and Effective Stress Diagrams up to 8 m below GL. Take $\gamma_w = 10 \text{ kN/m}^3$. (9 Marks)

Module – 3

15. (a) List the advantages and disadvantages of Direct Shear Test. (7 Marks)
 (b) A cylindrical specimen of soil fails under axial vertical stress of 150 kN/m^2 , when it is laterally unconfined. Failure plane makes an angle of 53° with the horizontal. Determine shear strength parameters c & ϕ . (7 Marks)
16. (a) Explain critical depth of an unsupported cut in a cohesive soil. (5 Marks)
 (b) A retaining wall 8m high with a smooth vertical back retains a sandy backfill ($\phi = 34^\circ$, Density of soil above water table is 18 kN/m^3 and below water table is 19 kN/m^3). Water table is at 3 m below ground level. Find the total active pressure per metre length of the wall and its point of application above the base by Rankine's theory. (9 Marks)

Module – 4

17. Explain different types of shallow foundations and list the advantages and disadvantages of each type of footings. (14 Marks)
18. (a) Explain various factors that affect ultimate bearing capacity of a shallow footing? (5 Marks)
 (b) A square footing of 2 m x 2 m is to be founded at a depth of 1.5 m in a soil with following data:
- | | | |
|--------------------------------|---------------------------|--------------------|
| $\gamma = 19 \text{ kN/m}^3$; | $C = 30 \text{ kN/m}^2$; | $\phi = 40^\circ$ |
| $N_c = 95.7$; | $N_q = 81.3$; | $N_\gamma = 100.4$ |
- Determine the net safe bearing capacity with a factor of safety of 3, when Water table is at
 (i) 0.75 m from ground level. (ii) 2.5 m from ground level. (9 Marks)

Module – 5

19. (a) What is meant by Immediate Settlement? How to determine this. (5 Marks)
 (b) A 3m square footing at a depth of 2m from ground level carries a net load intensity of 150 kN/m^2 . If a compressible clay layer 3m thick exists at a depth of 5m below the footing, determine the settlement of the footing due to consolidation of clay layer. Assume the water table at a depth of 3m below GL. For sand, density = 18 kN/m^3 above water table and

19 kN/m³ below water table. For clay layer, LL = 65%, w_n = 40% and G = 2.7. Take $\gamma_w = 10$ kN/m³. (9 Marks)

20. (a) What is meant by Allowable settlement? (5 Marks)

(b) The following are results of a standards proctor compaction test performed on a sample of soil

Water Content %	6	8	10	12	14	16
Bulk Density (kN/m ³)	17.7	19.8	21	21.3	20.9	20.2

Plot the water content – dry density curve and obtain Moisture content and Maximum dry density. Also plot the zero air voids curve. Take G = 2.65. (9 Marks)

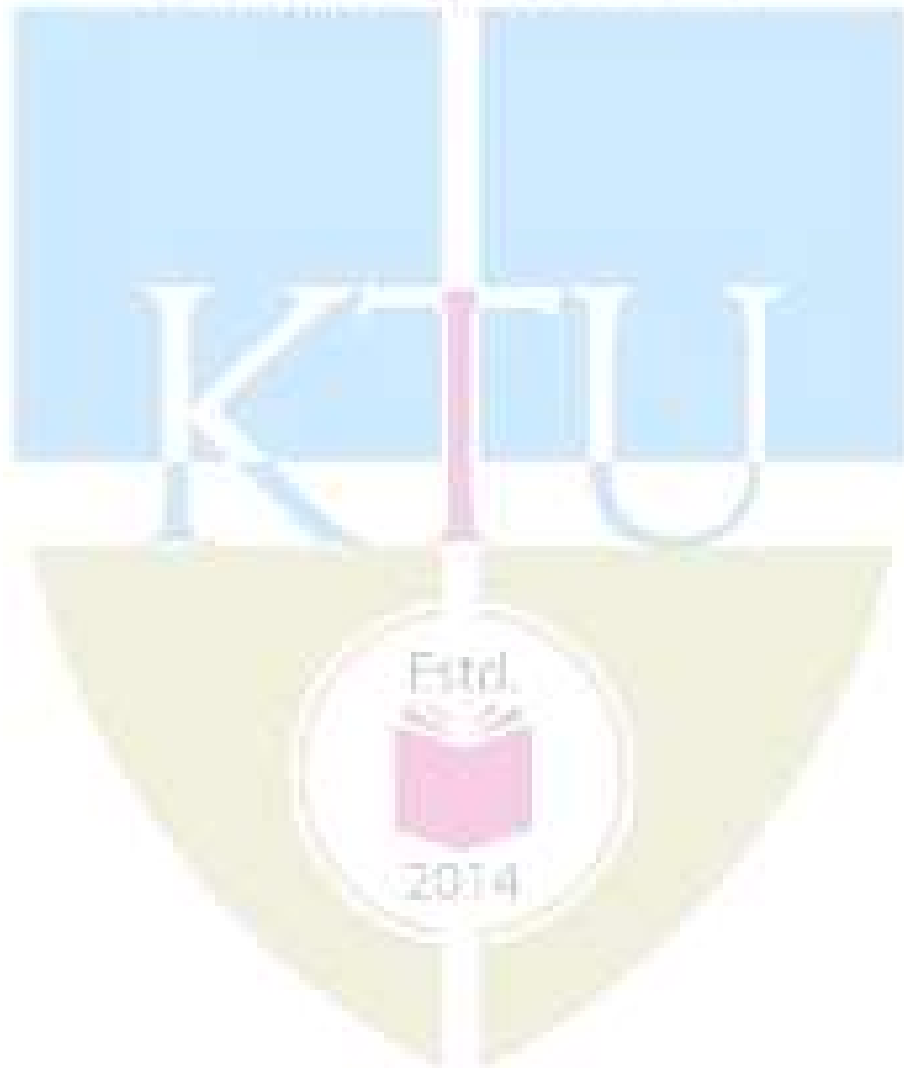

SYLLABUS

Module	Contents
1	<p>Introduction to soil mechanics - Soil types -Major soil deposits of India - 3 phase system - Basic soil properties: Void ratio, porosity, degree of saturation, air content, water content, specific gravity, unit weight - Relationship between basic soil properties - numerical problems.</p> <p>Laboratory Determination of Water content by oven drying; Specific gravity using pycnometer & specific gravity bottle and Field density by sand replacement method – Field density by Core Cutter method -</p> <p>Soil Structure: single grained, honey combed, flocculated and dispersed structure and their effects on the basic soil properties – Sensitivity and Thixotropy.</p>
2	<p>Index properties - Sieve analysis – Well graded, poorly graded and gap graded soils - Consistency - Atterberg Limits and Plasticity Index – Plasticity Chart –I.S. classification.</p> <p>Permeability of soils - Darcy’s law – Numerical Problems - Factors affecting permeability</p> <p>Principle of effective stress - Total, neutral and effective stress – Pressure diagrams - numerical problems</p> <p>Stress distribution - Boussinesq’s equations for vertical pressure due to point loads – Approximate methods for Vertical Pressure beneath rectangular shape: 2:1 Distribution Method - numerical problems -Isobars- Pressure bulbs</p>
3	<p>Shear strength of soils- Practical Applications - Mohr-Coulomb failure criterion – Mohr circle method for determination of principal planes and stresses– relationship between shear parameters and principal stresses [no derivation required] – Numerical Problems - Brief discussion of Direct shear test & UCC</p> <p>Lateral earth pressure – At-rest, active and passive earth pressures – Rankine’s theories [no derivation required] - Influence of surcharge, layered backfill and water table on earth pressure- numerical problems</p>
4	<p>Foundation - general consideration : Functions of foundations - Definition of shallow and deep foundations - Different types of foundations : Strip Footings; Isolated Footings; Combined Footings – Rectangular and Trapezoidal; Raft Foundations and Pile Foundations - Selection of type of foundation - Advantages and limitations of various types of foundations</p> <p>Bearing capacity of shallow foundations – Ultimate, safe and allowable bearing capacity. - Failure mechanism, assumptions and equation of Terzaghi’s bearing capacity theory for strip footing [no derivation required] – Bearing capacity factors and charts - Terzaghi’s formulae for circular and square footings - numerical problems - Local and general shear failure - Factors affecting bearing capacity – Effect of water table on bearing capacity - numerical problems -</p>
5	<p>Settlement analysis: Introduction - causes of settlement – immediate, consolidation and total settlement –Estimation of immediate settlement – Numerical Problems –</p> <p>Consolidation - Definition – Spring analogy for primary consolidation - Void ratio versus pressure relationship - Coefficient of compressibility and volume compressibility – Pre consolidation Pressure - Compression index-Estimation of magnitude of settlement of normally consolidated clays - Numerical problems</p> <p>Allowable settlement - Total and differential settlements as per Indian standard</p> <p>Compaction of soils - Difference between consolidation and compaction - IS Light & Heavy Compaction Tests – OMC and MDD</p>

Text Books:

1. Ranjan G. and A. S. R. Rao, Basic and Applied Soil Mechanics, New Age International, 2002.
2. Arora K. R., Geotechnical Engineering, Standard Publishers, 2006.

References:

1. Das B. M., Principles of Geotechnical Engineering, Cengage India Pvt. Ltd., 2010.
2. Venkatramaiah, Geotechnical Engg, Universities Press, 2000.
3. Terzaghi K. and R. B. Peck, Soil Mechanics in Engineering Practice, John Wiley, 1967.
4. A V Narasimha Rao and C Venkatramaiah, Numerical Problems, Examples and Objective questions in Geotechnical Engineering, Universities Press (India) Ltd., 2000
5. Purushothamaraj P., Soil Mechanics and Foundation Engineering, Dorling Indersley (India) Pvt. Ltd., 2013
6. Taylor D.W., Fundamentals of Soil Mechanics, Asia Publishing House, 1948.

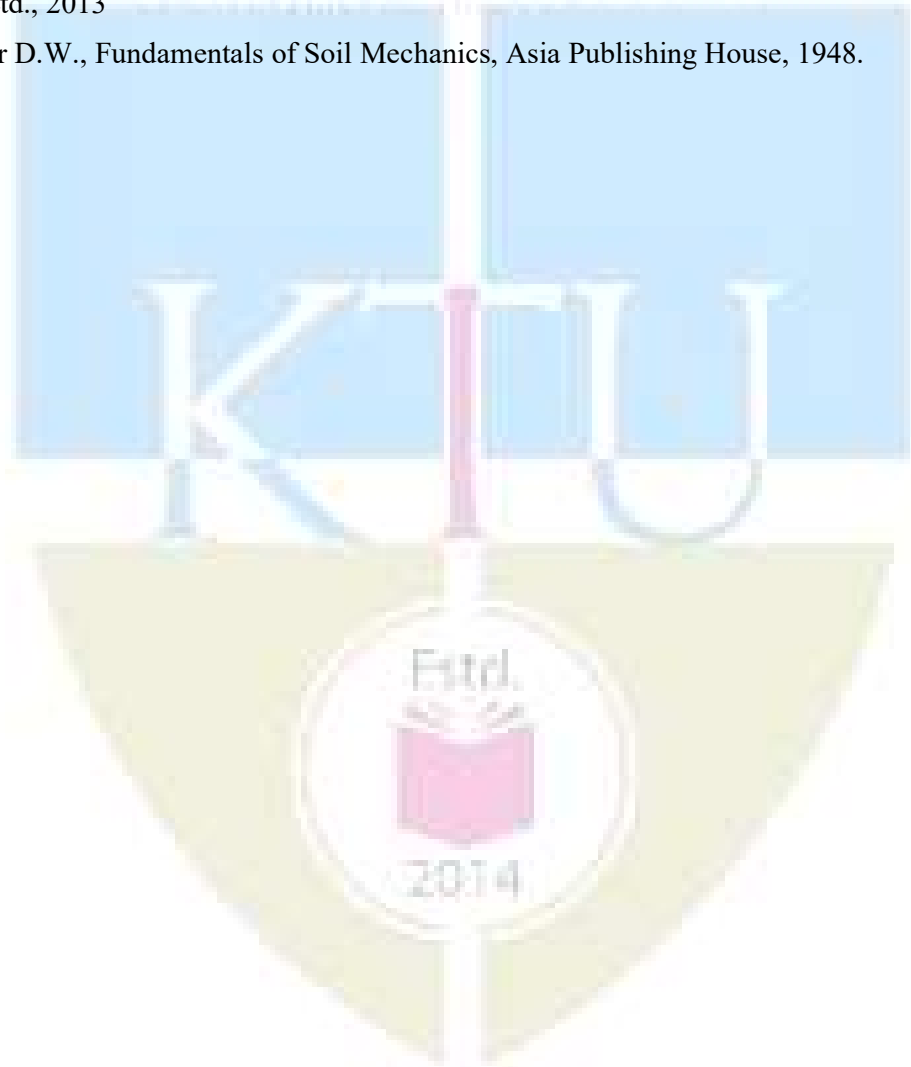

Course Contents and Lecture Schedule:

Module	Contents	Outcomes Addressed	Hours
1	Module 1		9
1.1	Nature of soil and functional relationships : Introduction to soil mechanics – Soil types – Major soil deposits of India	CO 1	1
1.2	3 phase system – Basic soil properties : Void ratio, porosity, degree of saturation, air content, water content, specific gravity, unit weight	CO 1	1
1.3	Relationship between basic soil properties	CO 1	1
1.4	Numerical problems	CO 2	2
1.5	Determination of Water content by oven drying, Specific gravity using pycnometer & specific gravity bottle	CO 1	1
1.6	Determination of Field density by sand replacement method & Core Cutter method	CO 1	1
1.7	Numerical problems	CO 2	1
1.8	Soil Structure and their effects on the basic soil properties – Sensitivity and Thixotropy	CO 1	1
2	Module 2		9
2.1	Index properties - Sieve analysis – Well graded, poorly graded and gap graded soils	CO 1	1
2.2	Consistency - Atterberg Limits and Plasticity Index	CO 1	1
2.3	Plasticity Chart –I.S. classification	CO 1	1
2.4	Permeability of soils - Darcy’s law – Factors affecting permeability	CO 1	1
2.5	Principle of effective stress - Total, neutral and effective stress – Pressure diagrams	CO 1	1
2.6	Numerical problems	CO 3	1
2.7	Stress distribution - Introduction - Boussinesq’s equations for vertical pressure due to point loads – Numerical problems	CO 1 & CO 3	1
2.8	Approximate methods for Vertical Pressure beneath rectangular shape: 2:1 Distribution Method - numerical problems	CO 1 & CO 3	1
2.9	Isobars- Pressure bulbs	CO 4	1
3	Module 3		9
3.1	Shear strength of soils- Practical Applications - Mohr-Coulomb failure criterion	CO 1	1
3.2	Mohr circle method for determination of principal planes and stresses–relationship between shear parameters and principal stresses [no derivation required]	CO 1	1
3.3	Numerical Problems	CO 3	
3.4	Brief discussion of Direct shear test & UCC	CO 1	1

3.5	Lateral earth pressure – At-rest, active and passive earth pressure	CO 1	1
3.6	Rankine’s theories [no derivation required]	CO 1	1
3.7	Influence of surcharge and water table on earth pressure	CO 1	1
3.8	Numerical problems	CO 4	1
3.9	Earth pressure on retaining walls with layered backfill – Numerical Problems	CO 1 & CO 4	1
4	Module 4		9
4.1	Foundations : Functions of foundations - Definition of shallow and deep foundations	CO 1	1
4.2	Different types of foundations : Strip Footings; Isolated Footings; Combined Footings – Rectangular & Trapezoidal; Raft Foundations and Pile Foundations	CO 1	1
4.3	Selection of type of foundation - Advantages and limitations of various types of foundations	CO 1	1
4.4	Bearing capacity of shallow foundations – Ultimate, safe and allowable bearing capacity.	CO 1	1
4.5	Failure mechanism, assumptions and equation of Terzaghi’s bearing capacity theory for strip footing [no derivation required]	CO 1	1
4.6	Bearing capacity factors and charts - Terzaghi’s formulae for circular and square footings -	CO 1	1
4.7	Numerical problems	CO 4	1
4.8	Effect of water table on bearing capacity - numerical problems	CO 1 & CO 4	1
4.9	Local and general shear failure - Factors affecting bearing capacity	CO 1	1
5	Module 5		9
5.1	Settlement analysis: Introduction - causes of settlement – immediate, consolidation and total settlement	CO 1	1
5.2	Estimation of immediate settlement – Numerical Problems	CO 1 & CO 4	1
5.3	Consolidation - Definition – Spring analogy for primary consolidation	CO 1	1
5.4	Void ratio versus pressure relationship - Coefficient of compressibility and volume compressibility – Pre consolidation Pressure - Compression index	CO 1	1
5.5	Estimation of magnitude of settlement of normally consolidated clays - Numerical problems	CO 4	1
5.6	Allowable settlement - Total and differential settlements as per Indian standard	CO 1	1
5.7	Compaction of soils - Difference between consolidation and compaction	CO 1	1
5.8	IS Light & Heavy Compaction Tests – OMC and MDD	CO 1	1
5.9	Numerical Problems	CO 3	1

CODE: CET 285	Course Name INFORMATICS FOR INFRASTRUCTURE MANAGEMENT	CATEGORY	L	T	P	CREDIT
		VAC	3	1	0	4

Preamble: This course is aimed at exposing the students to the scope of Informatics and Internet of Things (IoT) in Civil Engineering. It introduces students to the fundamentals of data analytics, informatics & IoT as it is applicable to civil engineering field. After this course, students will be in a position to appreciate the use of informatics & IoT in civil engineering projects and follow the future developments in this sector.

Prerequisite: NIL

Course Outcomes:

Course Outcome	Description of Course Outcome	Prescribed learning level
CO 1	To understand the fundamental concepts of data science, informatics & internet of things	Remembering, Understanding
CO 2	To learn the use of geomatics in planning and site selection of infrastructure projects	Applying & Analysing
CO 3	To apply building informatics in construction, monitoring and project management	Applying & Analysing
CO 4	To learn the role of IoT technology in infrastructure management	Applying & Analysing

Mapping of course outcomes with program outcomes (Minimum requirement)

	PO 1	PO 2	PO 3	PO 4	PO 5	PO 6	PO 7	PO 8	PO 9	PO 10	PO 11	PO 12
CO 1	2	-	-	-	-	-	-	-	-	-	-	-
CO 2	2	-	-	-	2	-	-	-	-	-	-	2
CO 3	2	-	-	-	2	-	-	-	-	-	-	2
CO 4	2	-	-	-	2	-	-	-	-	-	-	2

Assessment Pattern

Bloom's Category	Continuous Assessment Tests		End Semester Examination
	1	2	
Remember	10	10	15
Understand	10	10	15
Apply	15	15	35
Analyse	15	15	35
Evaluate			
Create			

Mark distribution

Total Marks	CIE	ESE	ESE Duration
150	50	100	3 hours

Continuous Internal Evaluation Pattern:

Attendance	: 10 marks
Continuous Assessment Test (2 numbers)	: 25 marks
Assignment/Quiz/Course project	: 15 marks

End Semester Examination Pattern: There will be two parts; Part A and Part B. Part A contain 10 questions with 2 questions from each module, having 3 marks for each question. Students should answer all questions. Part B contains 2 questions from each module of which student should answer any one. Each question carries 14 marks and can have maximum 2 sub-divisions.

Course Level Assessment Questions

(Questions may be framed based on the outline given under each course outcome)

Course Outcome 1 (CO1): *To understand the fundamental concepts of data science, informatics & internet of things.*

1. Explain DIKW pyramid.
2. Explain the data mining techniques
3. Discuss different data models
4. Discuss the vector data analysis techniques
5. Explain COBie standard
6. List IoT protocols
7. What are the elements of BIM?

Course Outcome 2 (CO2): *To learn the use of geomatics for planning and site selection of infrastructure projects.*

1. Discuss how geomatics help in site selection of a solid waste management facility
2. Discuss how terrain modeling is an important geographic information for project planning

Course Outcome 3 (CO3): *To apply building informatics in construction, monitoring and project management.*

1. How BIM helps in reducing the cost of construction?
2. Discuss the steps in developing a BIM for an infrastructure project.

Course Outcome 4 (CO4): *To learn the role of IoT technology in infrastructure management.*

1. How a water supply system could benefit by IoT technology?
2. Monitoring infrastructure projects could leverage from IoT technologies! Discuss.

Syllabus**Module 1 Data to Information**

History of informatics, DIKW pyramid, data management- data types, Meta data, database management systems; Data analysis techniques-spatial and non-spatial data, trends and patterns; Data mining techniques, data processing for information

Module 2 Geoinformatics

Fundamental concepts in Geo-informatics- Components, Spatial data and attributes, vector and raster data models, Methods of data input, Spatial data editing; Vector data analysis- buffering, overlay; Raster data analysis- local operations, neighborhood operations, zonal operations ; GIS output: cartographic and non-cartographic output

Module 3 Planning and Site selection

Site suitability analysis for Residential area, Industrial area, Recreational Area, Solid Waste Disposal, Water treatment plant, reservoirs;
Land use/ Land cover mapping, Ground Water Potential Zonation Mapping, Hazard Zonation Mapping, Terrain modelling
Network Analysis- Water supply line, Sewer line, Power line, Telecommunication, Road network

Module 4 Building Informatics

Building Information Modelling- Definition, Elements of BIM, steps in BIM development, COBie standard, potential and applications of BIM, Case studies

Module 5 Internet of Things (IoT) in Civil Infrastructure

IoT Standards & Protocols, Concept of IoT in civil engineering- Applications in construction, product monitoring and project Management
Smart Buildings- sensors & devices, selection criteria, data integration
Management Applications- Traffic Regulation, Water Supply, Pollution control, HVAC, Energy use

Text Books

1. J. Campbell, Essentials of Geographic Information Systems, Saylor Foundation, 2011.
2. RamezElmasri, ShamkantB.Navathe, "Fundamental of Database Systems", Pearson Addison Wesley, 2003.
3. BIM Handbook: A Guide to Building Information Modeling for Owners, Designers, Engineers, Contractors, and Facility Managers, Publisher: John Wiley & Sons; 2nd edition (1 July 2011), Language: English, ISBN-10: 9780470541371

Reference Books

1. Raja R. A. Issa and Svetlana Olbina, Building Information Modeling: Applications and Practices, ASCE, 2015.

2. Samuel Greengard, The internet of things, The MIT Press Essential Knowledge Series, 2015, ISBN: 978-0-262-52773-6.
3. ShashiShekhar and Sanjay Chawla,"Spatial Databases:A Tour", Prentice Hall, 2003.
4. Building Information Modeling: BIM in Current and Future Practice, Publisher: John Wiley & Sons; 1 edition (15 August 2014), Language: English, ISBN-10: 9781118766309

Lecture Plan – Informatics for Infrastructure Management

<i>Module</i>	<i>Topic</i>	<i>Course outcomes addressed</i>	<i>No. of Lectures</i>
1	Module I : Total lecture hours : 9		
1.1	History of informatics	CO1	Lecture 1
1.2	DIKW pyramid& Meta data	CO1	Lecture 2
1.3	Data management	CO1	Lecture 3
1.4	Data types & Meta data	CO1	Lecture 4
1.5	Database management systems	CO1	Lecture 5
1.6	Data analysis techniques	CO1	Lecture 6
1.7	Trends & Patterns in data analysis	CO1	Lecture 7
1.8	Data mining techniques	CO1	Lecture 8
1.9	Data processing for information	CO1	Lecture 9
2	Module II : Total lecture hours : 9		
2.1	Fundamental concepts in Geo-informatics-	CO1	Lecture 1
2.2	Components of GIS	CO1	Lecture 2
2.3	Spatial data and attributes	CO1	Lecture 3
2.4	Data models- vector & raster	CO1	Lecture 4
2.5	Methods of data input	CO1	Lecture 5
2.6	Spatial data editing	CO1	Lecture 6
2.7	Vector data analysis	CO1	Lecture 7
2.8	Raster data analysis- local & neighbourhood analysis	CO1	Lecture 8
2.9	Raster data analysis- zonal analysis& GIS output	CO1	Lecture 9

3	Module III : Total lecture hours : 9		
3.1	Site suitability analysis for Residential area,& Industrial area	CO2	Lecture 1
3.2	Site suitability analysis for recreational area & solid waste disposal	CO2	Lecture 2
3.3	Site suitability analysis for water treatment plant & reservoir	CO2	Lecture 3
3.4	Land use&land cover mapping	CO2	Lecture 4
3.5	Ground water potential zonation& Hazard zonation mapping	CO2	Lecture 5
3.6	Terrain modelling	CO2	Lecture 6
3.7	Network analysis for water supply & sewer lines	CO2	Lecture 7
3.8	Network analysis for power line & telecommunication	CO2	Lecture 8
3.9	Network analysis for road network	CO2	Lecture 9
4	Module IV : Total lecture hours : 9		
4.1	Building Information Modelling- Definition	CO3	Lecture 1
4.2	Elements of BIM	CO3	Lecture 2& 3
4.3	Steps in BIM development	CO3	Lecture 4 & 5
4.4	COBie standard	CO3	Lecture 6
4.5	Potential & applications of BIM	CO3	Lecture 7
4.6	Case studies of BIM	CO3	Lecture 8& 9
5	Module V : Total lecture hours : 9		
5.1	IoT Standards & Protocols, Concept of IoT in civil engineering	CO4	Lecture 1
5.2	Application of IoT in construction, product monitoring & project management	CO4	Lecture 2,3 & 4
5.3	Smart buildings	CO4	Lecture 5
5.5	Selection criteria of sensors & devices, Data integration	CO4	Lecture 6
5.7	Management applications of IoT- Traffic, water supply, pollution control, HVAC & energy use	CO4	Lecture7,8 & 9

QP CODE:

Reg No.: _____

Name: _____

APJ ABDUL KALAM TECHNOLOGICAL UNIVERSITY
THIRD SEMESTER B.TECH DEGREE EXAMINATION, MONTH & YEAR

Course Code:CET 285

Course Name: INFORMATICS FOR INFRASTRUCTURE MANAGEMENT

Max. Marks: 100

Duration: 3 hours

Part A

(Answer all questions; each question carries 3 marks)

1. Explain different data types.
2. Explain DIKW pyramid.
3. Compare vector & raster model.
4. What are the components of GIS?
5. Explain network analysis.
6. What is the importance of terrain modeling?
7. Define BIM.
8. What is COBie standard?
9. List the IoT protocols.
10. Explain the concept of smart buildings.

PART B

(Answer one full question from each module, each question carries 14 marks)

11. (a) Discuss data analysis techniques for spatial data. (5 Marks)
 (b) Explain the steps in processing data into information. (9 Marks)
- OR
12. (a) Briefly describe the history of informatics (5 Marks)
 (b) Explain various data mining techniques. (9 Marks)
13. (a) Discuss various data inputting methods for GIS (5 Marks)
 (b) Explain various vector analysis techniques. (9 Marks)
- OR
14. (a) Explain buffering analysis. What is its application? (5 Marks)
 (b) Explain various raster data analysis techniques. (9 Marks)

15. (a) How the site suitability analysis is carried out for a solid waste management facility? (7 Marks)
(b) Explain how geomatics is useful for mapping hazard zones. (7 Marks)

OR

16. (a) Explain the methodology for road network analysis. (7 Marks)
(b) Explain the process of converting data to information for a reservoir site selection. (7 Marks)
17. (a) What are the applications of BIM? (5 Marks)
(b) Discuss the steps in developing a BIM for an infrastructure project. (9 marks)

OR

18. (a) Explain the elements of BIM. (5 Marks)
(b) How BIM helps in reducing the cost of construction? (9 Marks)
19. (a) What sensors & devices would help in monitoring water distribution network. (5 Marks)
(b) Infrastructure management could leverage from IoT technologies! Discuss. (9 Marks)

OR

20. (a) What are the selection criteria for sensors & devices used in IoT technologies. (7 Marks)
(b) Discuss how IoT technologies could help in pollution control. (7 Marks)





SEMESTER -4

CET202	Engineering Geology	Category	L	T	P	Credits	Year of Introduction
		PCC	3	0	1		

Preamble: Goal of this course is to introduce to the students the basics of earth processes, materials, groundwater and the geological characteristics of such processes and materials which are relevant to the Civil Engineering applications.

Prerequisites: Nil

Course Outcomes: After completion of the course the student will be able to:

CO1	Recall the fundamental concepts of surface processes, subsurface process, minerals, rocks, groundwater and geological factors in civil engineering constructions.
CO2	Identify and describe the surface processes, subsurface process, earth materials, groundwater and geological factors in civil engineering constructions.
CO3	Apply the basic concepts of surface and subsurface processes, minerals, rocks, groundwater and geological characteristics in civil engineering constructions.
CO4	Analyze and classify geological processes, earth materials and groundwater.
CO5	Evaluation of geological factors in civil engineering constructions.

Mapping of course outcomes with program outcomes (Minimum requirement)

	PO1	PO2	PO3	PO4	PO5	PO6	PO7	PO8	PO9	PO10	PO11	PO12
CO1	2					1	2					
CO2	3											
CO3	3											
CO4	3	2										
CO5	3	1	3			3	3	2				2

Assessment pattern

Bloom's Category	Continuous Assessment Tests		End Semester Examination (Marks)
	Test 1 (Marks)	Test 2 (Marks)	
Remember	9 (3 marks for each question in which one question from third module)	6	15
Understand	6	9 (3 marks for each question in which one question from third module)	15
Apply	14 +14 + 7 (Question for 7 marks is from third module)	14 +14 + 7 (Question for 7 marks is from third module)	70
Analyse			
Evaluate			

Mark distribution

Total Marks	CIE marks	ESE marks	Test 1 &2 Duration	ESE Duration
150	50	100	1.5 hours	3 hours

Continuous Internal Evaluation Pattern:

Attendance: 10marks

Continuous Assessment Test (2 numbers): 25 marks

Assignment/Quiz/Courseproject: 15 marks

End Semester ExaminationPattern:

There will be two parts; Part A and Part B. Part A contain 10 questions with 2 questions from each module, having 3 marks for each question. Students should answer all questions. Part B contains 2 questions from each module of which student should answer any one. Each question can have maximum 2 sub-divisions and carry 14marks.

Course Level Assessment Questions:**Part A**

Course Outcome 1 (CO1): (One question from each module to meet the course objective 1: To recall the fundamental concepts of surface processes, subsurface process, minerals, rocks, groundwater and geological factors in civil engineering constructions).

1. Define weathering of rocks

Course Outcome 2 (CO2) (One question from each module to meet the course objective 2: To identify and describe the surface processes, subsurface process, earth materials, groundwater and geological factors in civil engineering constructions.)

1. Explain the classification of soil

Part B

All the questions under this section shall assess the learning levels corresponding to the course outcomes 3, 4 and 5.

1. a) Classify weathering and discuss the engineering classification of weathered rock masses (7 marks)
- b) Write your comments on the relevance of geology in civil engineering constructions (7 marks)

Model Question Paper

QP CODE:

RegNo.: _____

Name: _____

**PJ ABDUL KALAM TECHNOLOGICAL UNIVERSITY FIRST SEMESTER
B.TECH DEGREE EXAMINATION, MONTH & YEAR**

Course Code: CET 202

ENGINEERING GEOLOGY

Max.Marks: 100

Duration: 3hours

Part A

(Answer all questions; each question carries 3 marks)

1. Define weathering of rocks
2. Explain soil erosion and classification of soils
3. Describe earthquakes and write notes on seismograph and seismogram
4. Illustrate the elastic rebound theory with a diagram
5. Define Ghyben Herzberg relation in sea water intrusion
6. Explain Darcy's Law with a neat diagram
7. Write down the physical properties and chemical composition of given minerals
 - a. Calcite
 - b. Gypsum
8. Describe the different types of igneous rocks based on their origin
9. Illustrate the major parts of the fold with a neat diagram
10. Distinguish between clinometer compass and Brunton compass

PART B

(Answer one full question from each module, each question carries 14 marks)

Module -1

11. a) Discuss the relevance of geology in civil engineering constructions (7 marks)
b) Give an account on classification of weathering with suitable diagrams and examples (7 marks)
12. Describe the geological work of rivers. Discuss different landform features produced by weathering and river action with suitable diagrams. (14 marks)

Module -2

13. Comment on the relation of earthquakes with plate tectonics. Give an account on different plates with earthquake prone area (14 marks)

14. Discuss the various types of seismic waves and their relevance in the study of internal structure of earth. (14marks)

Module -3

15. Discuss the vertical distribution of groundwater. Give an account of the water bearing properties of rocks and hydrological cycle with neat diagrams. (14marks)
16. a) Elucidate application of electrical resistivity survey in ground water exploration. (8 marks)
- b) Give a brief account on different ground water recharge methods (6 marks)

Module -4

17. Distinguish between metamorphic and sedimentary rocks with respect to their structure with diagrams (14marks)
18. a) Elucidate various physical properties of minerals for their identification. (9marks)
- b) Give an account on hardness of minerals with Moh's hardness scale (5 marks)

Module -5

19. a) Enumerate the geological factors to be considered for selecting a dam site (9 marks)
- b) Discuss the geological conditions suitable and unsuitable for construction of tunnels (5marks)
20. Distinguish between folds and faults. Give an account on classification of folds with neat diagrams (14 marks)



ENGINEERING GEOLOGY

Syllabus

Module	Contents	Hours
Module 1 External Earth Processes	Relevance of Geology in Civil Engineering, Surface Processes of the earth- a) Weathering of rocks-Types of weathering, Processes of Origin of Products of weathering like sand, clay, laterite and soil, soil profile, Soil erosion and soil conservation measures. Engineering significance of weathering. b) Geological processes by rivers. c) Landslides-types, causes and controlling measures, Coastal Processes-Geological work by waves and currents and coastal protection measures	9
Module 2 Internal Earth Processes	Internal Processes of the earth- a) Earthquakes- Plate Tectonics, Origin of earthquakes, Seismic waves, Rating of earthquakes, types of earthquakes, Seismic zones of India. Basics of seismic safety factor, Interior of the earth as revealed by propagation of seismic waves.	9
Module 3 Groundwater	Hydrogeology- Occurrence of groundwater, aquifers and types of aquifers, confining beds, porosity and vertical distribution of groundwater. Darcy's Law. Permeability/hydraulic conductivity. Problems created by groundwater to civil engineering structures, Methods to control groundwater problems, Electrical resistivity survey for groundwater exploration. Seawater intrusion in Coastal area. Ghyben Herzberg relation.	9
Module 4 Earth Materials	Mineralogy- Physical properties of minerals, physical properties and chemical composition of minerals like quartz, orthoclase, plagioclase, biotite, muscovite, hornblende, augite, hypersthene, calcite, gypsum. Petrology- Igneous, sedimentary and metamorphic rocks, Igneous rocks-Chemical and mineralogical classification and structure. Sedimentary rocks-types based on mode of formation and structures Metamorphic rocks-structures only. Megascopic study of granite, dolerite, basalt, sandstone, limestone, shale, gneiss, marble and charnockite. Rock types of Kerala. Rock cycle	9
Module 5 Secondary Structures of Rocks	Structural Geology- Attitude of rocks – Dip and Strike. Terminology, brief classification and engineering significance of folds, faults and joints. Geological part of site investigation for the construction of dams, reservoirs and tunnels. Toposheet. Structural mapping. Clinometer compass and Brunton compass.	9

Textbooks

1. Duggal S.K, Pandey H.K and Rawat N (2014) Engineering Geology, Mcgraw Hill Education NewDelhi
2. Gokhale KVGK (2015) Principles of Engineering Geology, BS Publications, Hyderabad

3. Singh P (2014) Engineering and General Geology, SK Kataria and sons, NewDelhi
4. SubinoyGangopadhyay (2017) Engineering Geology, OxfordUniversity

References

1. David K Todd & Larry W Mays (2011) Groundwater Hydrogeology, Wiley India Pvt Ltd.
2. Gokhale N.W. (2015) Manual of Geological Maps, CBS Publishers, NewDelhi
3. Gribble CD (2005) Rutleys Elements of Mineralogy, Springer
4. Marland P Billings (2016), Structural Geology, Pearson education

Course Contents and Lecture Schedule:

Module	Topic	No. of hours
Module 1	Weathering of rocks-Types of weathering, Processes of Origin of Products of weathering like sand, clay, laterite and soil	3
	Soil profile, Soil erosion and soil conservation measures. Engineering significance of weathering.	2
	Geological processes by rivers. Landslides-types, causes and controlling measures	2
	Coastal Processes-Geological work by waves and currents and coastal protection measures	2
Module 2	Earthquakes- Plate Tectonics, Origin of earthquakes, Seismic waves, Rating of earthquakes, types of earthquakes	4
	Seismic zones of India. Basics of seismic safety factor	2
	Interior of the earth as revealed by propagation of seismic waves.	3
Module 3	Occurrence of groundwater, aquifers and types of aquifers, confining beds, porosity and vertical distribution of groundwater.	2
	Darcy's Law.Permeability/hydraulic conductivity. Problems created by groundwater to civil engineering structures	3
	Methods to control groundwater problems	1
	Electrical resistivity survey for groundwater exploration.	2
	Seawater intrusion in Coastal area. Ghyben Herzberg relation.	1
Module 4	Physical properties of minerals, physical properties and chemical composition of minerals like quartz, orthoclase, plagioclase, biotite, muscovite, hornblende, augite, hypersthene, calcite, gypsum	4

	Igneous, sedimentary and metamorphic rocks, Igneous rocks-Chemical and mineralogical classification and structure. Sedimentary rocks-types based on mode of formation and structures Metamorphic rocks-structures only. Megascopic study of granite, dolerite, basalt, sandstone, limestone, shale, gneiss, marble and charnockite. Rock types of Kerala. Rock cycle	5
Module 5	Attitude of rocks – Dip and Strike. Terminology	1
	Brief classification and engineering significance of folds, faults and joints	3
	Geological part of site investigation for the construction of dams, reservoirs and tunnels	3
	Toposheet, Structural mapping. Clinometer compass and Brunton compass	2



CET 204	GEOTECHNICAL ENGINEERING - I	CATEGORY	L	T	P	CREDIT	Year of Introduction
		PCC	4	0	0	4	2019

Preamble: Goal of this course is to expose the students to the fundamental concepts of soil mechanics and laboratory tests to determine the basic, index and engineering properties of soils. After this course, students will be able to identify and classify the soil and to recognize practical problems in real-world situations and respond accordingly.

Prerequisite : Nil

Course Outcomes: After completion of the course the student will be able to:

CO 1	Explain the fundamental concepts of basic and engineering properties of soil
CO 2	Describe the laboratory testing methods for determining soil parameters
CO 3	Solve the basic properties of soil by applying functional relationships
CO 4	Calculate the engineering properties of soil by applying the laboratory test results and the fundamental concepts of soil mechanics
CO 5	Analyze the soil properties to identify and classify the soil

Mapping of course outcomes with program outcomes (Minimum requirement)

	PO 1	PO 2	PO 3	PO 4	PO 5	PO 6	PO 7	PO 8	PO 9	PO 10	PO 11	PO 12
CO 1	3	-	-	-	-	-	-	-	-	-	-	-
CO 2	3	-	-	-	-	-	-	-	-	-	-	-
CO 3	2	3	-	-	-	-	-	-	-	-	-	-
CO 4	2	3	-	-	-	-	-	-	-	-	-	-
CO 5	2	3	-	-	-	-	-	-	-	-	-	-

Assessment Pattern

Bloom's Category	Continuous Assessment Tests		End Semester Examination (Marks)
	Test 1 (Marks)	Test 2 (Marks)	
Remember	10	10	20
Understand	10	15	20
Apply	25	25	50
Analyse	5		10
Evaluate			
Create			

Mark Distribution

Total Marks	CIE Marks	ESE Marks	ESE Duration
150	50	100	3 hours

Continuous Internal Evaluation (CIE) Pattern :

Attendance	: 10 Marks
Continuous Assessment Test (2 numbers)	: 25 Marks
Assignment/Quiz/Course project	: 15 Marks

End Semester Examination (ESE) Pattern : There will be two parts; Part A and Part B. Part A contains 10 questions with 2 questions from each module, having 3 marks for each question. Students should answer all questions. Part B contains 2 questions from each module of which student should answer any one. Each question can have maximum 2 sub-divisions and carry 14 marks.

Course Level Assessment Questions

(Questions may be framed based on the outline given under each course outcome)

Course Outcome 1 (CO1):

1. The fundamental concepts of basic properties and index properties of soil
2. The fundamental concepts of engineering properties of soils related to Permeability, consolidation, compaction & shear strength
3. Concepts of Total, neutral and effective stress; and vertical stress below loaded areas
4. Concepts of Slope stability

Course Outcome 2 (CO2):

1. The laboratory testing methods for determining basic and index soil properties
2. The laboratory testing methods for determining engineering properties related to Permeability, consolidation, compaction & shear strength

Course Outcome 3 (CO3):

1. Solve the basic properties of soil by applying functional relationships

Course Outcome 4 (CO4):

1. Calculate the engineering properties of soil related to Permeability, consolidation, compaction & shear strength by applying the laboratory test results
2. Calculate the settlement of footings due to consolidation and application of time rate of consolidation settlement
3. Calculate the engineering properties of soil by applying the concepts of soil mechanics related to total, neutral and effective stress; and vertical stress below loaded areas
4. Calculate the stability of slopes

Course Outcome 5 (CO5):

1. Identify and classify the soil by analysing the basic and index properties of soil

Model Question Paper

QP CODE:

Reg No.: _____

Name: _____

APJ ABDUL KALAM TECHNOLOGICAL UNIVERSITY
 FOURTH SEMESTER B.TECH DEGREE EXAMINATION, MONTH & YEAR

Course Code: CET 204

Course Name : GEOTECHNICAL ENGINEERING - I

Max. Marks: 100

Duration: 3 hours

Part A*(Answer all questions; each question carries 3 marks)*

1. Draw a three phase block diagram and define (i) Void Ratio, (ii) Water Content and (iii) Degree of saturation
2. Explain the procedure for Specific Gravity test using Pycnometer.
3. Define (i) Liquid Limit, (ii) Plastic Limit & (iii) Shrinkage Limit
4. Differentiate between Coefficient of Permeability and Coefficient of Percolation.
5. Explain Total Stress, Neutral Stress and Effective Stress.
6. List the assumptions of Boussinesq's theory.
7. Define pre consolidation pressure. Explain the method for the estimation of pre consolidation pressure.
8. Differentiate between Consolidation and Compaction.
9. Explain Mohr Coulomb shear strength theory.
10. What are the different types of slope failures?

PART B*(Answer one full question from each module, each question carries 14 marks)***Module – 1**

11. (a) Derive the relation between bulk unit weight, specific gravity, void ratio and degree of saturation from the fundamentals. (5 Marks)
- (b) A sample of wet silty clay soil weighs 1.26 kN. The following data were found from lab tests on the sample. Density $\gamma = 21 \text{ kN/m}^3$, Water content $w = 15\%$, Specific Gravity $G = 2.7$. Determine (i) Dry density, (ii) Void Ratio, (iii) Porosity (iv) Degree of Saturation, (v) Saturated unit weight (vi) Submerged unit weight and (vii) Volume of soil. (9 Marks)

12. (a) Explain different types of soil structures. (5 Marks)
- (b) 1000 cm³ core cutter weighing 9.46 N was used to find out the in-situ unit weight of soil in an embankment. The weight of core cutter with in-situ soil was noted to be 27.7 N. Laboratory tests on the sample indicated water content of 10% and specific gravity of solids of 2.63. Determine the bulk unit weight, dry unit weight, void ratio and degree of saturation. Also calculate the saturated unit weight and the corresponding water content if the embankment is saturated during rain without change in volume. (9 Marks)

Module – 2

13. (a) What is the use of particle size distribution curve? With the help of particle size distribution curve define the following terms (i) well graded soil (ii) poorly graded soil and (iii) gap graded soil. (5 Marks)
- (b) Tests on a fined grained soil sample indicated the following properties:
Liquid Limit = 52%, Plastic Limit = 32% and Shrinkage Limit = 17%. Classify the soil as per IS Code. If the specimen of this soil shrinks from a volume of 10 cm³ at Liquid Limit to 6 cm³ at the shrinkage limit, calculate the specific gravity of solids. (9 Marks)
14. (a) Explain the factors affecting permeability of soil. (5 Marks)
- (b) A soil sample of height 6 cm and area of cross section 100 cm² was subjected to constant head permeability test with head of 36 cm and 90 cc of water passes through the specimen during a test interval of 5 min. Compute the coefficient of permeability of the soil sample.
If the same sample is subjected to falling head permeability test and found that head drops from 60 cm to 20 cm in 4 min. Determine the cross sectional area of the stand pipe. (9 Marks)

Module – 3

15. (a) Explain Quick Sand Condition and Critical Hydraulic Gradient. (5 Marks)
- (b) A sand deposit of 8 m thick was loaded with a uniform surcharge of 10 kN/m². Water table (WT) is at 3 m below GL. Density of sand is 18 kN/m³ above WT and 19 kN/m³ below WT. Draw Total, Neutral and Effective Stress Diagrams up to 8 m below GL. Take $\gamma_w = 10 \text{ kN/m}^3$. (9 Marks)
16. (a) A concentrated load of 500 kN is applied at ground surface. Compute the vertical pressure (i) at a depth of 5m below the load, (ii) at a distance of 3m at the same depth. Use Boussinesq's theory. (7 Marks)
- (b) A water tank is founded on a circular ring type of foundation. The ring is of 2.5m width and its external diameter is 10m. Compute the vertical stress at 4m depth beneath the centre of the foundation, if pressure on the foundation is 100kPa. (7 Marks)

Module – 4

17. (a) A 8 m thick clay layer with double drainage settles by 120 mm in 2 years. $C_v = 1.5 \times 10^{-3} \text{ cm}^2/\text{sec}$. Calculate the likely ultimate consolidation settlement and find out how long it will take to undergo 90% of this settlement. (5 Marks)
- (b) A 3m square footing at a depth of 2m from ground level carries a net load intensity of 150 kN/m². If a compressible clay layer 3m thick exists at a depth of 5m below the footing, determine the settlement of the footing due to consolidation of clay layer. Assume the water table at a depth of 3m below GL. For sand, density = 18 kN/m³ above water table and

19 kN/m³ below water table. For clay layer, LL = 65%, w_n = 40% and G = 2.7. Take $\gamma_w = 10 \text{ kN/m}^3$. (9 Marks)

18. (a) Explain the field compaction methods. (5 Marks)

(b) The following are results of a standards proctor compaction test performed on a sample of soil

Water Content %	6	8	10	12	14	16
Bulk Density (kN/m ³)	17.7	19.8	21	21.3	20.9	20.2

Plot the water content – dry density curve and obtain Moisture content and Maximum dry density. Also plot the zero air voids curve. Take G = 2.65. (9 Marks)

Module – 5

19. (a) A cylindrical specimen of soil fails under axial vertical stress of 150 kN/m², when it is laterally unconfined. Failure plane makes an angle of 53° with the horizontal. Determine shear strength parameters c & ϕ . (5 Marks)

(b) Determine the shear strength parameters using the following data using graphical method:

Sample	Confining Pressure σ_c (kN/m ²)	Deviator Stress σ_d (kN/m ²)
1	100	600
2	200	750
3	300	900

(9 Marks)

20. (a) Explain the Swedish circle method for the analysis of slopes for a c- ϕ soil. (5 Marks)

(b) Determine factor of safety of vertical foundation trench 5m deep if c = 50 kN/m², $\phi = 25^\circ$, $\gamma = 17 \text{ kN/m}^3$. Assume Taylor's stability no. Sn = 0.166. (9 Marks)

SYLLABUS**Module 1**

Nature of soil and functional relationships : Introduction to soil mechanics – Soil types – Major soil deposits of India - 3 phase system – Basic soil properties : Void ratio, porosity, degree of saturation, air content, water content, specific gravity, unit weight - Relationship between basic soil properties - Numerical problems

Determination of Water content by oven drying, Specific gravity using pycnometer & specific gravity bottle - Determination of Field density by sand replacement method & Core Cutter method - Numerical problems

Soil Structure and their effects on the basic soil properties – Sensitivity and Thixotropy

Module 2

Index properties : Sieve analysis – Well graded, poorly graded and gap graded soils - Stoke's law – Hydrometer analysis [no derivation required for percentage finer and diameter] – Relative Density - Numerical problems - Consistency – Atterberg Limits and indices – Plasticity charts - laboratory tests for Liquid Limit, Plastic Limit & Shrinkage Limit - Numerical problems

IS classification of soil - Numerical problems

Permeability of soils : Darcy's law – Factors affecting permeability – Laboratory tests: Constant head and falling head permeability tests - Numerical problems - Average permeability of stratified deposits - numerical problems

Module 3

Principle of effective stress - Total, neutral and effective stress – Pressure diagrams - Numerical problems - Pressure diagrams in soils saturated by capillary action – Quick sand condition – Critical hydraulic gradient

Stress distribution : Introduction - Boussinesq's equations for vertical pressure due to point loads and line loads – Assumptions and Limitations - Numerical problems - Vertical pressure due to uniformly distributed loads beneath strip, circular and rectangular shapes [no derivation required] - Numerical problems

Approximate methods for vertical stress-distribution of contact pressure beneath footings : Equivalent Point Load method & 2:1 Distribution Method - Numerical problems - Pressure Isobars - Pressure bulbs – Newmark's charts (Construction procedure not required) and their use.

Module 4

Consolidation - Definition – Concepts of Coefficient of compressibility and volume compressibility - e-log p curve - Compression index, Recompression index and Pre consolidation Pressure - Normally consolidated, over consolidated and under consolidated soils - Estimation of magnitude of settlement of normally consolidated clays - Numerical problems

Terzaghi's theory of one-dimensional consolidation (no derivation required) - average degree of consolidation – Time factor - Coefficient of consolidation - Numerical problems - Laboratory consolidation test – Determination of Coefficient of Consolidation - Practical Applications

Compaction of soils - Difference between consolidation and compaction - IS Light & Heavy Compaction Tests – OMC and MDD - Zero Air voids line - Numerical problems - Control of

compaction - Field compaction methods - Proctor needle for field control

Module 5

Shear strength of soils- Practical Applications - Mohr-Coulomb failure criterion - Mohr circle method for determination of principal planes and stresses– relationship between shear parameters and principal stresses - Numerical problems

Brief discussion of Laboratory tests - Triaxial compression test - UU, CU and CD tests - Total and effective stress strength parameters - Unconfined compression test, Direct shear test and vane shear test – Applicability - Numerical problems

Stability of finite slopes - Toe failure, base failure, slip failure - Swedish Circle Method : $\phi=0$ analysis and $c-\phi$ analysis - Friction circle method - Taylor's Stability number - Stability charts - Numerical Problems

Text Books:

1. Ranjan G. and A. S. R. Rao, Basic and Applied Soil Mechanics, New Age International, 2002.
2. Arora K. R., Geotechnical Engineering, Standard Publishers, 2006.

References:

1. Das B. M., Principles of Geotechnical Engineering, Cengage India Pvt. Ltd., 2010.
2. Venkatramaiah, Geotechnical Engg, Universities Press, 2000.
3. Terzaghi K. and R. B. Peck, Soil Mechanics in Engineering Practice, John Wiley, 1967.
4. A V Narasimha Rao and C Venkatramaiah, Numerical Problems, Examples and Objective questions in Geotechnical Engineering, Universities Press (India) Ltd., 2000
5. Purushothamaraj P., Soil Mechanics and Foundation Engineering, Dorling Indersley (India) Pvt. Ltd., 2013
6. Taylor D.W., Fundamentals of Soil Mechanics, Asia Publishing House, 1948.

Course Contents and Lecture Schedule:

Module	Contents	Outcomes Addressed	Hours
1	Module 1		9
1.1	Nature of soil and functional relationships : Introduction to soil mechanics – Soil types – Major soil deposits of India	CO 1	1
1.2	3 phase system – Basic soil properties : Void ratio, porosity, degree of saturation, air content, water content, specific gravity, unit weight	CO 1	1
1.3	Relationship between basic soil properties	CO 1 & CO 3	1
1.4	Numerical problems	CO 3	2
1.5	Determination of Water content by oven drying, Specific gravity using pycnometer & specific gravity bottle	CO 2	1
1.6	Determination of Field density by sand replacement method & Core Cutter method	CO 2	1
1.7	Numerical problems	CO 3 & CO 4	1
1.8	Soil Structure and their effects on the basic soil properties – Sensitivity and Thixotropy	CO 1 & CO 5	1
2	Module 2		9
2.1	Index properties : Sieve analysis – Well graded, poorly graded and gap graded soils	CO 1 & CO 2	1
2.2	Stoke's law – Hydrometer analysis [no derivation required for percentage finer and diameter] – Relative Density	CO 1 & CO 2	1
2.3	Numerical problems	CO 4	1
2.4	Consistency – Atterberg Limits and indices – Plasticity charts - laboratory tests for Liquid Limit, Plastic Limit & Shrinkage Limit	CO 1 & CO 2	1
2.5	Numerical problems	CO 4	1
2.6	IS classification of soil - Numerical problems	CO 1 & CO 5	1
2.7	Permeability of soils : Darcy's law – Factors affecting permeability – Laboratory tests: Constant head and falling head permeability tests	CO 1 & CO 4	1
2.8	Numerical problems	CO 4	1
2.9	Average permeability of stratified deposits - numerical problems	CO 1 & CO 4	1
3	Module 3		9
3.1	Principle of effective stress - Total, neutral and effective stress – Pressure diagrams	CO 1	1
3.2	Numerical problems	CO 4	1
3.3	Pressure diagrams in soils saturated by capillary action – Quick sand condition – Critical hydraulic gradient	CO 1	1
3.4	Stress distribution : Introduction - Boussinesq's equations for vertical pressure due to point loads and line loads – Assumptions and Limitations	CO 1	1

3.5	Numerical problems	CO 4	1
3.6	Vertical pressure due to uniformly distributed loads beneath strip, circular and rectangular shapes [no derivation required]	CO 1	1
3.7	Numerical problems	CO 4	1
3.8	Approximate methods for vertical stress-distribution of contact pressure beneath footings : Equivalent Point Load method & 2:1 Distribution Method - Numerical problems	CO 1 & CO 4	1
3.9	Pressure Isobars - Pressure bulbs – Newmark’s charts (Construction procedure not required) and their use.	CO 1	1
4	Module 4		9
4.1	Consolidation - Definition – Concepts of Coefficient of compressibility and volume compressibility - e-log p curve - Compression index, Recompression index and Pre consolidation Pressure	CO 1	1
4.2	Normally consolidated, over consolidated and under consolidated soils - Estimation of magnitude of settlement of normally consolidated clays	CO 1 & CO 4	1
4.3	Numerical problems	CO 4	1
4.4	Terzaghi’s theory of one-dimensional consolidation (no derivation required) - average degree of consolidation – Time factor - Coefficient of consolidation	CO 1 & CO 4	1
4.5	Numerical problems	CO 4	1
4.6	Laboratory consolidation test – Determination of Coefficient of Consolidation - Practical Applications	CO 2 & CO 4	1
4.7	Compaction of soils - Difference between consolidation and compaction - IS Light & Heavy Compaction Tests – OMC and MDD - Zero Air voids line	CO 1, CO2 & CO 4	1
4.8	Numerical problems	CO 4	1
4.9	Control of compaction - Field compaction methods - Proctor needle for field control	CO 1	1
5	Module 5		9
5.1	Shear strength of soils- Practical Applications - Mohr-Coulomb failure criterion	CO 1	1
5.2	Mohr circle method for determination of principal planes and stresses– relationship between shear parameters and principal stresses	CO 1 & CO 4	1
5.3	Numerical problems	CO 4	1
5.4	Brief discussion of Laboratory tests - Triaxial compression test - UU, CU and CD tests - Total and effective stress strength parameters	CO 2 & CO 4	1
5.5	Unconfined compression test, Direct shear test and vane shear test – Applicability	CO 2 & CO 4	1
5.6	Numerical problems	CO 4	1
5.7	Stability of finite slopes - Toe failure, base failure, slip failure	CO 1	1
5.8	Swedish Circle Method : $\phi=0$ analysis and c- ϕ analysis - Friction circle method	CO 1 & CO 4	1

5.9	Taylor's Stability number - Stability charts - Numerical Problems	CO 1 & CO 4	1
-----	---	-------------	---



CIVIL ENGINEERING

CET206	TRANSPORTATION ENGINEERING	CATEGORY	L	T	P	CREDIT	YEAR OF INTRODUCTION
		PCC	4	0	0	4	2019

Preamble

Objective of the course is to introduce the principles and practice of Highway, Railway, Harbour and dock, Tunnel and Airport Engineering.

Prerequisite: Nil

Course Outcomes:

	Description
CO No.	At the end of the course, students will be able to:
CO 1	Apply the basic principles of Highway planning and design highway geometric elements
CO 2	Apply standard code specifications in judging the quality of highway materials; designing of flexible pavements
CO 3	Explain phenomena in road traffic by collection, analysis and interpretation of traffic data through surveys; creative design of traffic control facilities
CO 4	Understand about railway systems, tunnel, harbour and docks
CO 5	Express basics of airport engineering and design airport elements

Mapping of course outcomes with program outcomes

	PO1	PO2	PO3	PO4	PO5	PO6	PO7	PO8	PO9	PO10	PO11	PO12
CO 1	3	3	3	1		1	3	1		2		1
CO 2	3	1	3	1		1	1	1		1		1
CO 3	3	2	2	1					1	2		2
CO 4	2						2	1				2
CO 5	3	3	3			3		2				

Assessment Pattern

Bloom's Category	Continuous Assessment		End Semester Examination (marks)
	Test 1 Marks	Test 2 Marks	
Remember	7.5	7.5	30
Understand	7.5	7.5	30
Apply	5	5	20
Analyse	5	5	20
Evaluate			
Create			

Mark Distribution

Total Marks	CIE (Marks)	ESE (Marks)	ESE Duration
150	50	100	3 hours

Continuous Internal Evaluation Pattern:

Attendance	: 10 marks
Continuous Assessment Test (2 numbers)	: 25 marks
Assignment/Quiz/Course Project	: 15 marks

End Semester Examination Pattern:

The question consists of two parts- Part A and Part B. Part A consists of 10 questions with 3 marks for each (two questions from each module). Part B consists of two questions from each module, out of which one has to be answered. Each question carries 14 marks and can have maximum 2 subdivisions.

Sample Course Level Assessment Questions:

1 Course Outcome 1 (CO1): While aligning a highway in a built up area, it was necessary to provide a horizontal curve of radius 300 m for a design speed 65Km/hr, length of wheel base-6m and pavement width 10.5m. Assume rate of introduction of super elevation as 1 in 100 and super elevation is provided by rotating about centre line. Design super elevation, extra widening of pavement and length of transition curve.

2 Course Outcome 2 (CO2): Design a flexible pavement for two lane single carriage way for present traffic 1200 commercial vehicles per day, period of construction= 3 yrs, annual traffic growth = 7.5%, Design CBR = 7%, Design life = 15 yrs. Use IRC method.

3 Course Outcome 3 (CO3): Traffic in a congested multilane highway lane is observed to have an average spacing of 200 ft, and an average headway of 3.8s. Estimate the rate of flow, density and speed of traffic in this lane.

4 Course Outcome 4 (CO4):

Sketch the component parts of a permanent way and mark the salient points

5 Course Outcome 5 (CO5): The total length of a runway is 1000 m. The elevation at distance 0,200 m, 400 m, 600 m, 800 m and 1000 m are 100.0 m, 99.2 m, 101.0 m, 101.8 m, 101.4 m and 101.0 m respectively. What will be the effective gradient of runway?

Syllabus

Module	Contents	Hours
1	Introduction to Transportation Engineering, Classification of roads, Typical cross sections of roads in urban and rural area, Requirements and factors controlling alignment of roads Introduction to geometric design of highways, Design controls and criteria, Design of highway cross section elements, Design of horizontal alignment - Stopping sight distance, Overtaking sight distance, super elevation, transition curve, length and shift of transition curve, extra widening. Vertical alignment (introduction only)	10
2	Introduction to highway materials, Desirable properties and testing of road aggregates, bituminous materials and sub grade soil. Introduction of flexible and rigid pavements, Factors influencing the design of flexible pavements, Design of flexible pavements by CBR method and IRC 37: 2018. Construction of bituminous pavements	9
3	Introduction to traffic engineering, Traffic characteristics, Capacity and Level of Service, Design Speed, Traffic surveys, Types of road intersections, Traffic control devices (introduction only), Design of isolated signals by Webster’s method.	7
4	Railway Engineering - Component parts of a railway track - functions, concept of Gauges, coning of wheels, cant deficiency, compensation of gradients Tunnel Engineering: Tunnel – sections, tunnel surveying - alignment, transferring centre grade into tunnel. Harbours – classification, features, requirements. Break waters - necessity and functions, classification. Docks – Functions and types - dry docks, wet docks (Introduction only)	8
5	Introduction to Airport Engineering, Components of airport, selection of site for airport. Runway orientation, basic runway length and corrections required, Taxiways and aprons.	8

Text Books

1. Khanna, S.K. and Justo C.E.G., Highway Engineering, Nem Chand & Bros., 2015
2. Kadiyali, L. R. and N.B Lal, Principles and Practices of Highway Engineering, Khanna Publishers, 2013
3. Khanna, S. K. and Arora. M. G., Airport Planning and Design, Nemchand& Bros
4. Mundrey J. S, Railway Track Engineering, Tata McGraw Hill, 2009

5. Rangawala, S.C. , Railway Engineering, Charotar Publishing House
6. Rao G. V, Principles of Transportation and Highway Engineering, Tata McGrawHill, 1996
7. Srinivasan,R., Harbour, Dock & Tunnel Engineering, Charotar Publishing House, 28e, 2016

References

1. Horonjeff R. and McKelvy, F., Planning and Design of Airports, McGraw Hill, 5e, 2010
2. IRC: 37-2018, Guidelines for the Design of Flexible Pavements, IRC 2018, New Delhi
3. O' Flaherty, C.A (Ed.), Transport Planning and Traffic Engineering, Elsevier, 1997
4. Rangwala, S. C., Airport Engg. Charotar Publishing Co., 16e, 2016
5. Yoder, E. J and Witczak, M. W, Principles of Pavement Design, John Wiley & Sons, 1991
6. Bindra, S.P., A course in Docks and Harbour Engineering, Dhanpat Rai& Sons
7. Chandra, S. and Agarwal, M.M., Railway Engineering, Oxford University Press, New Delhi, 2008
8. Saxena, S. C and Arora, S. P, Railway Engineering, Dhanpat Rai& Sons, 7e, 2010
9. Subhash C. Saxena, Railway Engineering, Dhanpat Rai& Sons

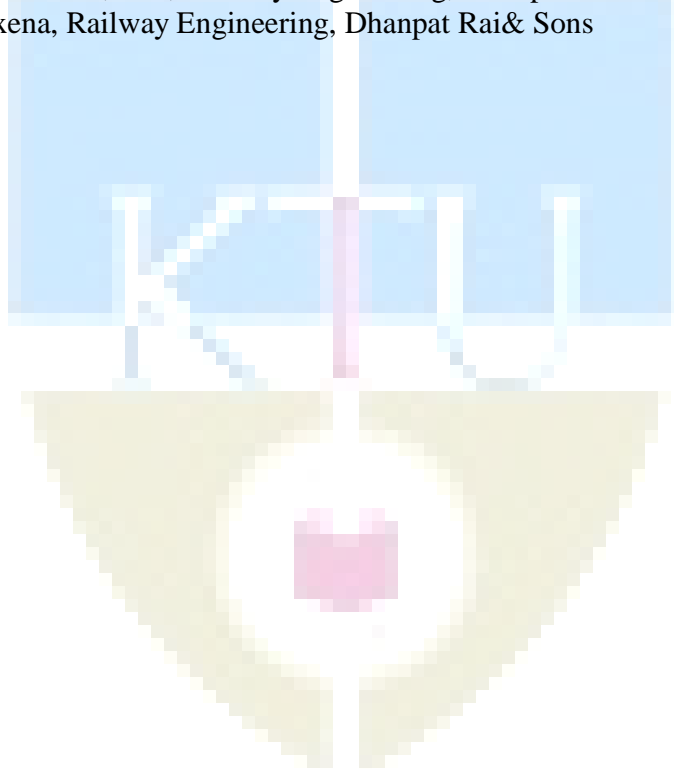

Course Content and lecture Schedule:

No.	Topic	Course Outcome	No. of Hrs
1	Module 1		Total: 10
1.1	Introduction to Transportation Engineering, Classification of roads, Typical cross sections of roads in urban and rural area, Requirements and factors controlling alignment of roads.	CO1	2
1.2	Introduction to geometric design of highways, Design controls and criteria, Design of highway cross section elements	CO1	2
1.3	Design of horizontal alignment - Stopping sight distance, Overtaking sight distance, super elevation, transition curve, length and shift of transition curve, extra widening. Vertical alignment (introduction only)	CO1	6
2	Module 2		Total: 9
2.1	Introduction to highway materials, Desirable properties and testing of road aggregates, bituminous materials and sub grade soil.	CO2	3
2.2	Introduction of flexible and rigid pavements, Factors influencing the design of flexible pavements, Design of flexible pavements by CBR method and IRC 37 : 2018	CO2	3
2.3	Construction of bituminous pavements	CO2	3
3	Module 3		Total: 7
3.1	Introduction to traffic engineering, Traffic characteristics, Capacity and Level of Service, Design Speed, Traffic surveys, Types of road intersections,	CO3	4
3.2	Traffic control devices (introduction only), Design of isolated signals by Webster's method.	CO3	3
4	Module 4		Total: 8
4.1	Railway Engineering - Component parts of a railway track - functions, concept of Gauges, coning of wheels, cant deficiency, compensation of gradients	CO4	4
4.2	Tunnel Engineering: Tunnel – sections, tunnel surveying - alignment, transferring centre grade into tunnel.	CO4	2
4.3	Harbours – classification, features, requirements. Break waters - necessity and functions, classification. Docks – Functions and types - dry docks, wet docks (Introduction only)	CO4	2
5	Module 5		Total: 8
5.1	Introduction to Airport Engineering, Components of airport, selection of site for airport.	CO5	3
5.2	Runway orientation, basic runway length and corrections required, Taxiways and aprons.	CO5	5

**APJ ABDUL KALAM TECHNOLOGICAL UNIVERSITY
THIRD SEMESTER B. TECH DEGREE EXAMINATION, MONTH & YEAR**

Course Code: **CET 206**

Course Name: **TRANSPORTATION ENGINEERING**

Model Question Paper

Marks:100

Duration: 3 hrs

PART A

(Answer all questions. Each question carry three marks)

1. With a sketch, explain typical cross sectional layout of a two lane road in urban areas.
2. What is meant by reaction time? What is its role in Geometric design of highways?
3. Outline the IRC 37- 2018 recommendations for determining the thickness of Flexible pavements.
4. Differentiate flexible and rigid pavements
5. How would you draw the fundamental diagram of traffic flow
6. Explain grade separated intersections and discuss the advantages and limitations
7. Analyse the concept of cant deficiency with suitable explanations
8. Write short note on Littoral Drift
9. Enumerate the various factors which would be kept in view while selecting suitable site for an airport.
10. What are taxiways?

PART B

(Answer one full question from each module)

11. a) Enumerate the factors governing the width of carriage way. State the IRC specifications for width of carriage way for various classes of roads. (10)
- b) Write a brief note on classification of highways in India. (4)

OR

12. a) Calculate the stopping sight distance on a highway for a design speed of 100 kmph. (6)
- b) What is super elevation? Explain the design steps of super elevation. (8)

13a) Explain the construction practices of the following bituminous base courses.

- 1) Bituminous macadam
- 2) Penetration macadam (6)

b) The soil subgrade sample was obtained from the project site and the CBR tests conducted at field density gave the following readings. Draw the load penetration curve and determine the CBR value and find the total thickness of the pavement by CBR method as recommended by IRC for commercial vehicles 1500 per day, with 7% growth rate. The pavement construction is to be completed in three years after last traffic count. (Use the standard design chart provided)

(8)

Penetration (mm)	Load (kg)	Penetration (mm)	Load (kg)
0.0	0.0	3.0	60.0
0.5	6.0	4.0	70.0
1.0	17.0	5.0	77.0
1.5	30.0	7.5	89.0
2.0	42.0	10.0	100.0
2.5	55.0	12.5	115.0

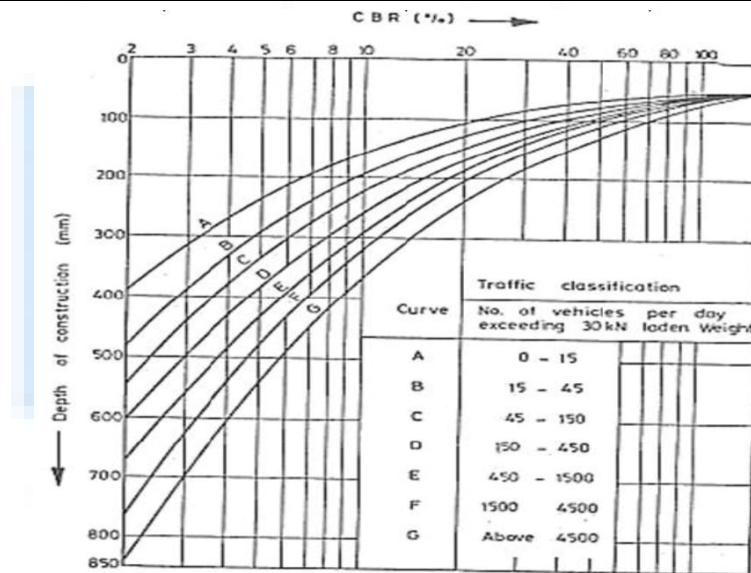

OR

- 14 a) Explain in detail the various factors that influencing the design of flexible pavements? (10)
 b) List out the desirable properties of aggregates to be used in pavement construction. Also specify various tests for judging the suitability of aggregates. (4)

- 15 a) What are the advantages and disadvantages of traffic signals? (8)
 b) What is (i) Saturation flow, (ii) Lost time, and (iii) Phase in a signal design? (6)

OR

- 16 a) Define the basic terms basic capacity, possible capacity and practical capacity and analyze its importance in traffic engineering. (6)
 b) Evaluate the factors affecting level of service of a multilane highway. (8)

- 17 a) Analyse various types of gradient used on railway track. What is grade compensation and why is it necessary? (6)
 b) State the natural and meteorological phenomena a harbour engineer has to study and briefly mention the effects of these phenomena (8)

OR

- 18 a) Explain the functions of rails, sleepers and ballast. (8)
 b) What are the classifications of tunneling? (6)
- 19 a) Explain in detail about the functions of taxiways and aprons. (6)
 b) What are the factors to be considered in the orientation of runway? (8)

OR

- 20 a) What are the factors affecting selection of site for airport? (4)
 b) The length of a runway under standard conditions is 1500m. The airport is to be provided at an elevation of 110m above mean sea level. The airport reference temperature is 32°C. Following data refers to the proposed longitudinal section of runway. Determine the corrected length of runway. (10)

End to end of runway (m)	Grade (%)	End to end of runway (m)	Grade (%)
0 to 300	+1	1500 to 1800	+1
300 to 900	-0.2	1800 to 2100	-0.3
900 to 1500	+0.5		

CEL 202	MATERIAL TESTING LAB - I	CATEGORY	L	T	P	CREDIT	YEAR OF INTRODUCTION
		PCC	0	0	3	2	2019

Preamble: The course aims to enrich the understanding of the fundamental concepts of mechanics of deformable bodies through systematic experimental techniques for the estimation of various mechanical properties of engineering materials.

Prerequisite: Engineering Physics, Mechanics of Materials. Knowledge in use of Vernier caliper and micrometer screw gauge expected.

General Instructions to Faculty:

1. Any 12 experiments out of 15 need to be performed mandatorily. Virtual Lab facility [11] cannot be used to substitute the conduct of these mandatory experiments.
2. The laboratory should have possession of modern testing equipment such as strain gauges, LVDTs, load cells and data acquisition systems at least for demonstration purposes
3. Periodic maintenance and calibration of various testing instruments needs to be made.
4. Use of data visualization packages needs to be promoted for making various plots.

Course Outcomes: After the completion of the course, the student will be able to:

Course Outcome	Course Outcome Description
CO 1	The understand the behaviour of engineering materials under various forms and stages of loading.
CO 2	Characterize the elastic properties of various materials.
CO3	Evaluate the strength and stiffness properties of engineering materials under various loading conditions.

Mapping of course outcomes with program outcomes:

CO/PO	PO 1	PO 2	PO 3	PO 4	PO 5	PO 6	PO 7	PO 8	PO 9	PO 10	PO 11	PO 12
CO 1	3	2	2	2	1	3	-	-	2	2	-	2
CO 2	3	2	2	2	1	3	-	-	2	2	-	2
CO 3	3	2	2	2	1	3	-	-	2	2	-	2

Course Level Assessment Questions**Assessment Pattern****Mark distribution**

Total Marks	CIE	ESE	ESE Duration
150	75	75	2.5 hours

Continuous Internal Evaluation Pattern:

Attendance	:	15 marks
Continuous Assessment	:	30 marks
Internal Test (Immediately before the second series test)	:	30 marks

End Semester Examination Pattern: The following guidelines should be followed regarding award of marks

(a) Preliminary work	:	15 Marks
(b) Implementing the work/Conducting the experiment	:	10 Marks
(c) Performance, result and inference (usage of equipment and trouble shooting)	:	25 Marks
(d) Viva voce	:	20 marks
(e) Record	:	5 Marks

General instructions:

Practical examination to be conducted immediately after the second series test covering entire syllabus given below. Evaluation is a serious process that is to be conducted under the equal responsibility of both the internal and external examiners. The number of candidates evaluated per day should not exceed 20. Students shall be allowed for the University examination only on submitting the duly certified record. The external examiner shall endorse the record.

References

1. S.P. Timoshenko, *History of Strength of Materials*, Dover publications, 1953
2. Egor P. Popov, *Engineering Mechanics of Solids*, Pearson, 1998.
3. IS 1608 (2005): *Metallic Materials – Tensile testing at Ambient temperature*, 3rd Revision, July 2008
4. IS 1598 (1977): *Method for Izod Impact test of Metals*, 2nd reprint, September 1986.
5. IS 1499 (1977) : *Method for Charpy Impact test (U-Notch) for metals*, 3rd reprint, March 1992.

6. IS 5242 (1979) Method of Test for determining Shear Strength of Metals, 1st revision, 2006.
7. IS 1500 (2005): Method for Brinell Hardness Test for Metallic Materials, 3rd revision, 2005.
8. IS 1501 (2002) : Method for Vickers hardness Test for Metallic Materials.
9. IS 1717 (2012): Metallic Materials – Wire – Simple Torsion Test, 3rd revision, 2012.
10. IS 883 (1994): Design of Structural Timber in Building- Code of Practice, Reaffirmed 2005)
11. www.vlab.co.in

SYLLABUS

- Exercise 1. Study on stress-strain characteristics of mild steel and by conducting uniaxial tension test on rod specimens
- Exercise 2. Study on stress-strain characteristics of tor steel by conducting uniaxial tension test on rod specimens
- Exercise 3. Study on estimation of shear capacity of mild steel specimen by conducting a double shear test on rod specimen.
- Exercise 4. Study on flexural behaviour of steel by conduction of test on RSJ (I cross section)
- Exercise 5. Study on torsional behaviour and estimation of modulus of rigidity of steel by conducting torsion test on rod specimens
- Exercise 6. Study on estimation of modulus of rigidity of steel and brass / copper materials utilizing the principles of torsional vibrations.
- Exercise 7. Study on estimation of toughness properties of steel specimens by conducting (a) Izod &(b) Charpy impact tests.
- Exercise 8. Study on estimation of hardness properties of engineering materials such as brass, aluminium, copper, steel etc.by performing Brinell hardness test
- Exercise 9. Study on estimation of Hardness properties of engineering materials such as brass, aluminium, copper, steel etc.by performing

9.1 Rockwell hardness test

9.2 Vicker's hardness test

Exercise 10. Study on estimation of modulus of rigidity of steel by performing tension tests on spring specimens.

Exercise 11. Study on estimation of modulus of rigidity of steel by performing compression tests on spring specimens

Exercise 12. Study on flexural behaviour of timber material by performing tests on beam specimens.

Exercise 13. Study on estimation of compression strength of timber specimen.

Exercise 14. Experiment on verification of Maxwell's reciprocal theorem

Exercise 15. Bend & rebend test on mild steel specimen

Optional Exercises:

Study/ demonstration of :

- Fatigue test on steel rod specimen
- Strain gauges and Load cells
- Elastic buckling modes of column under different boundary conditions

CEL 204	FLUID MECHANICS LAB	CATEGORY	L	T	P	CREDIT	YEAR OF INTRODUCTION
		PCC	0	0	3	2	2019

Preamble: The course is designed to train the students to familiarize and understand the different flow measurement equipment's and their procedures. Students will be introduced to a team working environment where they develop the necessary skills of experimentation techniques for the study of flow phenomena in channels/pipes.

Prerequisite: Fluid Mechanics and Hydraulics

Course Outcomes: After the completion of the course, the student will be able to:

Course Outcome (CO)	Course Outcome Description
CO 1	Apply fundamental knowledge of Fluid Mechanics to corresponding experiments
CO 2	Apply theoretical concepts in Fluid Mechanics to respective experiments
CO 3	Analyse experimental data and interpret the results
CO 4	Document the experimentation in prescribed manner

Mapping of course outcomes (COs) with program outcomes (POs)

CO/PO	PO 1	PO 2	PO 3	PO 4	PO 5	PO 6	PO 7	PO 8	PO 9	PO 10	PO 11	PO 12
CO 1	2	2	-	-	-	-	-	2	3	-	-	-
CO 2	2	2	-	-	-	-	-	2	3	-	-	-
CO 3	3	3	-	2	-	-	-	2	3	3	-	-
CO 4	1	-	-	-	-	-	-	2	2	3	-	-

Course Level Assessment Questions

Assessment Pattern

Mark distribution

Total Marks	Continuous Internal Evaluation (CIE)	End Semester Examination (ESE)	End Semester Examination (ESE) Duration
150	75	75	2.5 hours

Continuous Internal Evaluation Pattern:

Attendance	: 15 marks
Continuous Assessment	: 30 marks
Internal Test (Immediately before the second series test)	: 30 marks

End Semester Examination Pattern: The following guidelines should be followed regarding award of marks.

- | | |
|---|------------|
| a) Preliminary work | : 15 marks |
| b) Implementing the work/ Conducting the experiment | : 10 marks |
| c) Performance, result and inference (usage of equipments and trouble shooting) | : 25 marks |
| d) Viva voce | : 20 marks |
| e) Record | : 5 marks |

General Instructions:

Practical examination to be conducted immediately after the second series test covering entire syllabus given below. Evaluation is a serious process that is to be conducted under the equal responsibility of both the internal and external examiners. The number of candidates evaluated per day should not exceed 20. Students shall be allowed for the University examination only on submitting the duly certified record. The external examiner shall endorse the record.

Reference Books:

1. Modi P. N. and S. M. Seth, Hydraulics & Fluid Mechanics, S.B.H Publishers, New Delhi, 2002.
2. Subramanya K., Theory and Applications of Fluid Mechanics, Tata McGraw-Hill, 1993.
3. Subramanya K., Flow in Open channels, Tata McGraw-Hill, 2009.

List of Exercises/ Experiments (Any 12 experiments out of 15 need to be performed mandatorily. Lab experiments may be given considering 12 sessions of 3 hours each)

1. Study of taps, valves, pipe fittings, gauges, Pitot tubes, water meters and current meters.
2. Calibration of Pressure gauges
3. Determination of metacentric height and radius of gyration of floating bodies.
4. Verification of Bernoulli's theorem
5. Hydraulic coefficients of orifices and mouth pieces under constant head method and time of emptying method.
6. Calibration of Venturimeter

7. Calibration of Orifice meter
8. Calibration of water meter.
9. Calibration of rectangular notch
10. Calibration of triangular notch.
11. Time of Emptying through orifice
12. Plotting Specific Energy Curves in Open Channel flow
13. Study of Parameters of Hydraulic Jump in Open channel Flow.
14. Determination of friction co-efficient in pipes
15. Determination of loss co-efficient for pipe fittings

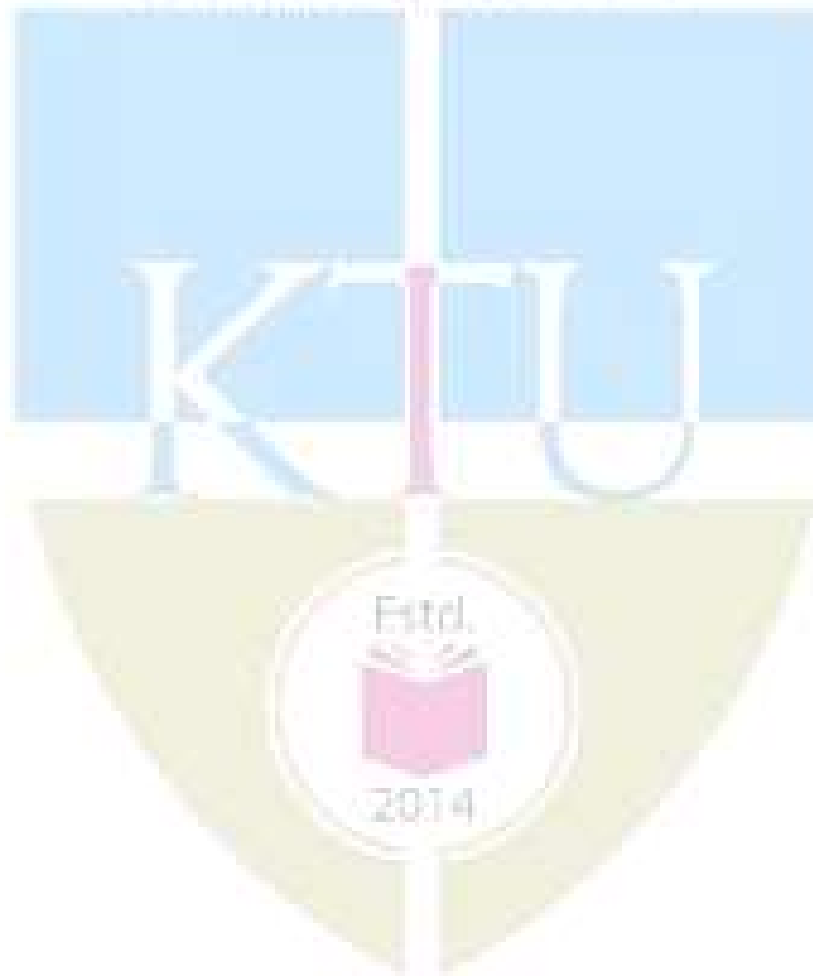

ATTA ABDUL KALAM
TECHNOLOGICAL
UNIVERSITY

SEMESTER -4
MINOR



Mark distribution

Total marks	CIE Marks	ESE Marks	ESE duration
150	50	100	3 hours

Continuous internal evaluation Pattern:

Attendance : 10 marks

Continuous Assessment Test (2 numbers) : 25 marks

Assignment/Quiz/Course Project : 15 marks

End Semester Examination Pattern: ESE will be of **3 hour** duration on A2 size answer booklet and will be for 100 marks. (only manual drafting for ESE). 5 descriptive type questions of 2 marks each, one from each module. 2 drawing questions of 45 marks each, with choice from 4, from any 4 modules.

Syllabus**Module 1**

General – Study of IS Codes of practice on building drawing – Scales- method of dimensioning.

Sectional plan, sectional elevation, front view and joint details of Panelled door and Glazed windows.

Module 2

Types of Roof- Roofing- Elevation and joint details-Roof truss in steel sections.

Types of Stairs- Plan and sectional elevation of reinforced concrete staircase.

Module 3

Building rules- Two storied and multi-storeyed building- Plan, section and elevation.

Public buildings like offices, bank, dispensary etc.

Module 4

Building rules -Industrial building- Plan, section and elevation.

Preparation of site plan and service plan.

Module 5

Preparation of Septic tank and soak pit -detailed drawing.

Course Content and lecturer Schedule:

No.	Course Plan	Course Outcome	No. ofHrs
	Module 1:		
1.1	General – Study of IS Codes of practice on building drawing	CO1	2
1.2	Scales- method of dimensioning		2
1.3	Sectional plan, sectional elevation, front view and joint details of	CO2	
1.4	(a)Panelled doors		2
1.5	(b)Glazed windows		2
	Module 2:		
2.1	Types of Roofs	CO2	2
2.2	Roof truss in steel sections		2
2.3	Types of Stairs	CO3	2
2.4	Reinforced concrete staircase		2
	Module 3:		
3.1	Building rules Plan, section and elevation of	CO4	2
3.2	(a) Two storied building		2
3.3	(b) multi-storeyed building		2
3.4	(c) Public building		2

	Module 4:		
4.1	Building rules and type of Industrial building	CO4	2
4.2	Plan elevation and section of industrial building		2
4.3	Preparation of site plan		2
4.4	service plan	CO5	2
	Module 5:		
5.1	Preparation of Septic tank and soak pit -detailed drawing	CO5	2

Reference Books

1. National Building Code of India.
2. Kerala Municipal Building Rules.
3. Dr. Balagopal T.S. Prabhu, Building Drawing and Detailing, Spades Publishers, Calicut.

Model Question Paper

QP CODE:

Reg No:-----

Name:-----

**APJ ABDUL KALAM TECHNOLOGICAL UNIVERSITY FIRST SEMESTER B.TECH
DEGREE EXAMINATION, MONTH & YEAR**Course Code: **CET282****BUILDING DRAWING**

Max. Marks: 100

Duration: 3 hours

Part A**(Answer all questions; each question carries 2 marks)**

1. Draw neat sketches for following lines; (a) Section line (b) Hidden line (c) Dimension line (d) Extension line
2. What are the major components of a steel truss?
3. What is the difference between waist slab and folded slab stair?
4. What is FAR and FSI?
5. State the importance of site plan and openings schedule in civil engineering drawing.

PART B**(Answer Two full question, each question carries 45 marks)**

6. Draw the elevation and sectional view of a double leaf and six paneled door of size 2000x1200 mm
7. Plan a RCC stair case for a room dimension 450 cm x 300 cm. Draw plan view and sectional view. Take floor height =3m.
8. Single stored residential house with the following requirements & draw plan, elevation and section.
(i) Verandah (ii) Bed room (3 no's), one with attached toilet (iii) living hall (iv) kitchen (v) work area (vi) common toilet
9. Draw the plan and elevation of a small hospital for the following requirements;

(i) Doctor's room (2)	(ii) causality
(iii) Dressing area	(iv) Pharmacy
(v) Laboratory	(vi) Store room
(vii) Toilets	(viii) ward (5 bed)

CET284	INTRODUCTION TO TRANSPORTATION ENGINEERING	CATEGORY	L	T	P	CREDIT	YEAR OF INTRODUCTION
		VAC	4	0	0	4	2019

Preamble

Objective of the course is to introduce the principles and practice of Highway, Traffic Engineering and Transportation Planning.

Prerequisite: Nil

Course Outcomes:

	Description
CO No.	At the end of the course, students will be able to:
1	Discuss the basic characteristics of Highways and basics of geometric design.
2	Analyse the features of highway materials , various types of pavements, and construction techniques
3	Interpret the basics of traffic characteristics, describe how to conduct traffic surveys and interpret data, understand the various traffic control devices
4	Establish the basics of different modes of transportation and their characteristics including rail, water and air.
5	Appraise Travel Demand Estimation process and the sustainable transportation measures and its application through promoting public transportation modes.

Mapping of course outcomes with program outcomes

	PO1	PO2	PO3	PO4	PO5	PO6	PO7	PO8	PO9	PO10	PO11	PO12
1	3	1	2			1	1	1		1		1
2	3	1				1	1	1		1		1
3	3	1	1			1	1	1	1	1		1
4	2	1				1	1	1		1	1	1
5	3	3				2	3	1	1	1	1	1

Assessment Pattern

Bloom's Category	Continuous Assessment		End Semester Examination (marks)
	Test 1 Marks	Test 2 Marks	
Remember	10	10	30
Understand	10	10	30
Apply	5	5	40
Analyse			
Evaluate			
Create			

Mark Distribution

Total Marks	CIE (Marks)	ESE (Marks)	ESE Duration
150	50	100	3 hours

Continuous Internal Evaluation Pattern:

Attendance	: 10 marks
Continuous Assessment Test (2 numbers)	: 25 marks
Assignment/Quiz/Course Project	: 15 marks

End Semester Examination Pattern:

The question consists of two parts- Part A and Part B. Part A consists of 5 questions with 5 marks for each (one questions from each module). Part B consists of two questions from each module, out of which one has to be answered. Each question carries 15 marks and can have maximum 3 subdivisions.

Course Level Assessment Questions:

Course Outcome 1 (CO1):What are the basic requirements for an ideal highway alignment? Describe the factors considered in finalising the alignment.

Course Outcome 2 (CO2):Describe the specifications of materials and construction steps of bituminous concrete pavements.

Course Outcome 3 (CO3):Explain the effect of various vehicular characteristics on traffic stream behaviour.

Course Outcome 4 (CO4): Sketch the typical layout of an airport showing the location of taxiways, runways, apron and terminal building for a two open parallel runways.

Course Outcome 5 (CO5): What are the options available in present day society to make transportation sustainable? What are the steps to be adopted by the stakeholders to implement it in India?

SYLLABUS

Mod	Contents	Hrs
1	Introduction to Transportation Engineering, Role of transportation in the development of a society, Classification of roads, Typical cross sections of roads in urban and rural area, Introduction to geometric design of highways, highway cross section elements	9
2	Introduction of flexible and rigid pavements. Introduction to highway materials, Desirable properties and testing of road aggregates, bituminous materials and sub grade soil. Construction of bituminous pavements and rigid pavements (Basics only)	9
3	Introduction to traffic engineering, Traffic characteristics, Capacity and Level of Service, Design Speed, Traffic signals and markings, Types of road intersections, Traffic control devices (introduction only)	8
4	Railway Engineering - Component parts of a railway track - functions, concept of Gauges, coning of wheels Harbours – classification, features, requirements. Break waters - necessity and functions, classification. Docks – Functions and types - dry docks, wet docks (Introduction only) Airport Engineering:- Components of airport and airport layout, Runway orientation, Taxiways, aprons. and Terminal Building (Introduction only)	12
5	Transportation Planning:-Need for Transportation planning, Transport- land use interaction, Travel Demand Estimation –(Introduction only) Sustainable urban transport; issues and challenges, Emerging concepts in sustainable transportation: green vehicles and green roads, green and alternate fuels;	7

Text Books

1. Khanna, S.K. & Justo E.G., Highway Engineering, Nem Chand & Bros., 2000
2. Kadiyali, L. R., Traffic Engineering& Transportation Planning, Khanna Publishers, 2017
3. Khanna, S. K. and Arora. M. G., Airport Planning and Design, Nemchand& Bros
4. Rangawala, S.C. , Railway Engineering, Charotar Publishing House
5. Rao G. V, Principles of Transportation and Highway Engineering, Tata McGrawHill, 1996
6. Srinivasan,R., Harbour, Dock & Tunnel Engineering, Charotar Publishing House, 28e, 2016

References

1. Partho Chakraborty and Animesh Das, Principles of Transportation Engineering,
2. IRC: 37-2001, Guidelines for the Design of Flexible Pavements, IRC 2001, New Delhi
3. IRC:37-2012, Tentative Guidelines for the Design of Flexible Pavements , PHI, 2017
4. O' Flaherty, C.A (Ed.), Transport Planning and Traffic Engineering, Elsevier, 1997
5. C S Papacostas and P D Prevedouros, Transportation Engineering and Planning, 2007
6. Yoder, E. J & Witezak, M. W, Principles of Pavement Design, John Wiley & Sons, 1991
7. Sustainable Urban Transport Shanghai Manual – A Guide for Sustainable Urban Development in the 21st Century

Course Content and lecture Schedule:			
No.	Topic	Course Outcome	No. of Hrs
1	Module 1		Total: 9
1.1	Introduction to Transportation Engineering, Role of transportation in the development of a society, Various fields of Transportation Engineering	CO1	2
1.2	Classification of roads, Typical cross sections of roads in urban and rural area,	CO1	3
1.3	Introduction to geometric design of highways, highway cross section elements, Horizontal alignment and Vertical alignment (introduction only)	CO1	4
2	Module 2		Total:9
2.1	Introduction of flexible and rigid pavements	CO2	2
2.2	Introduction to highway materials, Desirable properties and testing of road aggregates	CO2	4
2.3	Construction of bituminous pavement sand rigid pavements (Basics only)	CO2	3
3	Module 3		Total: 8
3.1	Introduction to traffic engineering, Traffic characteristics	CO3	2
3.2	Capacity and Level of Service, Design Speed	CO3	2
3.3	Traffic signals and markings	CO3	2
3.4	Types of road intersections, Traffic control devices (introduction only)	CO3	2
4	Module 4		Total: 12
4.1	Railway Engineering - Component parts of a railway track functions, concept of Gauges, coning of wheels	CO4	4
4.2	Harbours – classification, features, requirements. Break waters - necessity and functions, classification. Docks – Functions and types - dry docks, wet docks (Introduction only)	CO4	4
4.3	Introduction to Airport Engineering, Components of airport, Runway orientation, Taxiways and aprons and Terminal Building	CO4	4
5	Module 5		Total: 7
5.1	Need for Transportation planning, Transport- land use interaction	CO5	1
5.2	Travel Demand Estimation - Steps in 4 stage planning process	CO5	2
5.3	Sustainable urban transport; issues and challenges	CO5	1
5.4	Policy options for urban transport- Push and pull approach, NMT planning, Transit oriented development	CO5	2
5.5	Emerging concepts in sustainable transportation: green vehicles and green roads, green and alternate fuels;	CO5	1

**APJ ABDUL KALAM TECHNOLOGICAL UNIVERSITY
FOURTH SEMESTER B. TECH DEGREE EXAMINATION, MONTH & YEAR**

Course Code: **CET284**

Course Name: **INTRODUCTION TO TRANSPORTATION ENGINEERING**

Model Question Paper

Marks:100

Duration: 3 hrs

PART A

(Answer all Questions: Each question carries 3 marks)

- 1 What is the role of roads in Indian economy?
- 2 Explain briefly the classification of highways in India.
- 3 Differentiate flexible and rigid pavement
- 4 Differentiate tack coat and prime coat. What are the objectives of application of each?
- 5 Distinguish between traffic capacity, basic capacity and practical capacity.
- 6 Discuss about the requirements of traffic control devices.
- 7 List and define the component parts of a railway track.
- 8 What are the detrimental forces acting on a break water?
- 9 List the role of transportation planning to society
- 10 What are the advantages of green fuel?

(3 x 10=30 marks)

PART B

(Answer one full question from each module)

- | | | |
|-----------|---|---|
| 11 a. | What are the factors controlling the alignment of highways? Explain the influence each of them in detail? | 7 |
| b. | Discuss about the various cross section elements to be considered in the geometric design of highways? | 7 |
| OR | | |
| 12 a. | Design the rate of super elevation for a horizontal highway curve of radius 500 m and speed 100 kmph | 7 |
| b. | What is overtaking sight distance? Derive the equation for OSD. | 7 |
| OR | | |
| 13 a. | Differentiate flexible and rigid pavements. Sketch a typical section for each. | 7 |
| b. | Discuss the desirable properties of aggregates used for road construction. | 7 |
| OR | | |
| 14 a. | Discuss any three properties of bitumen and their effect on the performance of bituminous mixes in pavements. | 7 |
| b. | What are the factors to be considered in design of flexible pavements and indicate their significance? | 7 |

- 15 a. Explain the effect of various vehicular characteristics on traffic stream behaviour. 7
b. Draw a typical Speed-flow diagram and indicate the Levels of service as per IRC. 7
- OR**
- 16 a. What are the advantages and disadvantages of traffic signals? 7
b. Enumerate the basic types of intersections and basic principles involved. 7
- 17 a. Explain with neat sketches the concept of coning of wheels. 7
b. How are harbours classified? Explain with sketches any two types. 7
- OR**
- 18 a. Distinguish between wet docks and dry docks? What are its functions? 7
b. Enumerate the factors that are to be considered for site selection of an airport? 7
- 19 a. Enumerate how land use and transportation planning are inter related. 7
b. Briefly explain the various stages in travel demand estimation 7
- OR**
- 20 a. What are the ways to overcome the issues and challenges in transportation? 7
b. How can green vehicles and green roads contribute to sustainable transportation? 7

CET 286	Climate Change and Hazard Mitigation	Category	L	T	P	Credit	Year of Introduction
		VAC	4	0	0	4	2019

Preamble: The course is designed to build climate literacy among students, encourages them to adapt to climate change related issues. It helps learners to understand the fundamentals of climate, climate change and climate models, evaluate the impacts of climate change on ecosystems, and empower learners to take appropriate actions to adopt various hazard mitigation measures.

Pre-requisite: Nil

Course outcome

After the course, the student will able to:

CO1	Explain the basic physical principles of the global climate system.
CO2	Describe the large-scale climatic changes which has influenced the ecosystem.
CO3	List actions in key sectors to mitigate hazards due to climate change.
CO4	Identify international initiatives which support countries to address the climate change challenges.
CO5	Analyse the impact of climate change on ecosystem.

CET 256 Climate Change and Hazard Mitigation		PO1	PO2	PO3	PO4	PO5	PO6	PO7	PO8	PO9	PO10	PO11	PO12	PSO1	PSO2	PSO3
	CO1	3					2	1							1	
	CO2	3					2	1								
	CO3	3					2	1								
	CO4	3					2									
	CO5	3					2	1								

Assessment pattern

Bloom's Category	Continuous Assessment Tests		End Semester Examination (Marks)
	Test 1 (Marks)	Test 2 (Marks)	
Remember	15	15	30
Understand	20	20	40
Apply			
Analyze	15	15	30
Evaluate			
Create			

Continuous Internal Evaluation Pattern:

Attendance	:	10 marks
Continuous Assessment Test(2 numbers)	:	25 marks
Assignment/Quiz/Course project	:	15 marks
Total	:	50 marks

End semester examination pattern – There will be two parts; Part A and Part B. Part A contain 10 questions with 2 questions from each module, having 3 marks for each question. Students should answer all questions. Part B contains 2 questions from each module of which student should answer any one. Each question can have maximum 2 subdivisions and carry 14 marks.

Course Level Assessment

Qn No	Question	Marks	Course outcome (CO) Assessed
Part A			
1	Define climate system.	3	CO1
2	How does Albedo affect climate of a place?	3	CO1
3	Briefly explain El Nino and its effects.	3	CO2

4	What is carbon cycling?	3	CO2
5	Describe about General Circulation Models.	3	CO5
6	Comment on Ocean Acidification.	3	CO5
7	Discuss the mission of Intergovernmental Panel on Climate Change.	3	CO4
8	What is Montreal Protocol?	3	CO4
9	Briefly explain Carbon dioxide Capture and Storage.	3	CO3
10	Discuss the importance of bio energy crops.	3	CO3
Part B			
(Answer ANY ONE FULL question from each module)			
Module I			
11(a)	What is the general circulation of the atmosphere?	7	CO1
11(b)	How does the general circulation affect the earth's climate?	7	CO1
12(a)	What is the composition and structure of the atmosphere?	7	CO1
12(b)	Explain the significance of water in the atmosphere on climate of earth.	7	CO1
Module II			
13(a)	State and explain Global Warming Potential.	7	CO2
13(b)	Briefly explain Gandhian ideas on Global warming.	7	CO2
14(a)	Describe the importance of Greenhouse effect on global climate system.	7	CO2

14(b)	Discuss the role of carbon dioxide in Greenhouse effect	7	CO2
Module III			
15	Briefly explain the impact of climate change on surface temperature and precipitation.	14	CO5
16	Describe the different uncertainties inherent in the projection of climate.	14	CO5
Module IV			
17	Enumerate the international initiatives to address climate change challenges and explain any two.	14	CO4
18(a)	Outline the structure of the Intergovernmental Panel on Climate Change.	4	CO4
18(b)	Explain the comprehensive Assessment Reports of IPCC.	10	CO4
Module V			
19 (a)	Explain hazards due to climate change and describe the possible mitigation measures to it.	14	CO3
20 (a)	Discuss the concept of energy efficiency in buildings in response to climate change.	5	CO3
20 (b)	Discuss the impact of climate change on Ecosystem and its adaptation measures.	9	CO3

Model Question Paper

Reg No.:.....

QP CODE:.....

Name:.....

**APJ ABDUL KALAM TECHNOLOGICAL UNIVERSITY
THIRD SEMESTER B.TECH DEGREE EXAMINATION, MONTH & YEAR**

Course Code: CET 286

Climate Change and Hazard Mitigation

Max. Marks: 100

Duration: 3 hours

Part A**(Answer all questions; each question carries 3 marks)**

1. Define climate system.
2. How does Albedo affect climate?
3. Briefly explain El Nino and its effects.
4. What is carbon cycling?
5. Describe about General Circulation Models.
6. Comment on Ocean Acidification.
7. Discuss the mission of Intergovernmental Panel on Climate Change.
8. What is Montreal Protocol?
9. Briefly explain Carbon dioxide Capture and Storage.
10. Discuss the importance of bio energy crops.

Part B**(Answer one full question from each module; each question carries 14 marks)****Module I**

11. a) What is the general circulation of the atmosphere? (7 Marks)
b) How does the general circulation affect the earth's climate? (7 Marks)

OR

12. a) What is the composition and structure of the atmosphere? (7 Marks)
b) Explain the significance of water in the atmosphere on climate of earth. (7 Marks)

Module II

13. (a) State and explain Global Warming Potential. (7 Marks)
b) Briefly explain Gandhian ideas on Global warming. (7 Marks)

OR

14. (a) Describe the importance of Greenhouse effect on global climate system. (7 Marks)
b) Discuss the role of carbon dioxide in Greenhouse effect. (7 Marks)

Module III

15. Explain the impact of climate change on surface temperature and precipitation. (14 Marks)

OR

16. Describe the different uncertainties inherent in the projection of climate. (14 Marks)

Module IV

17. Enumerate the international initiatives to address climate change challenges and explain any two. (14 Marks)

OR

18. a) Outline the structure of the Intergovernmental Panel on Climate Change. (4 Marks)
b) Explain the comprehensive Assessment Reports of IPCC. (10 Marks)

Module V

19. Explain hazards due to climate change and describe the possible mitigation measures to it. (14 Marks)

OR

20. (a) Discuss the concept of energy efficiency in buildings in response to climate change. (5 Marks)
b) Discuss the impact of climate change on Ecosystem and its adaptation measures. (9 Marks)

Course Code: CET 286
Climate Change and Hazard Mitigation

Module I

Introduction to Earth's Climate System: Basic concepts- Radiation, Albedo, Emissivity, scales of motion, large-scale motion, general circulation, troposphere-stratosphere transport. Atmospheric structure and thermodynamics: pressure, density, composition, temperature structure, water in the atmosphere. Atmospheric photochemistry and chemical kinetics

Module II

Hurricanes and Global warming: Global Ocean Circulation - El Nino and its effects - Paleo- indicators of climate -The Nature of Storms—cyclones, tornadoes and hurricanes. Greenhouse effect-greenhouse gases-sources of emission - The Role of Carbon Dioxide, The Earth's Carbon Reservoirs, Carbon Cycling-Climate and Weather Global warming potential - Effects of Global warming- Gandhian ideas on global warming.

Module III

Climate data and Models: Equations of atmospheric fluid mechanics, energy equation, turbulence, mixing length models, Atmospheric chemical transport and general circulation models. Analyses of climate data. Climate projections and their uncertainties. Impacts of climate change on Surface temperature, Precipitation, Ocean pH, Sea-level and Arctic sea-ice extent.

Module IV

International initiatives to address the climate change challenges: History of Earth's climate – 1970s (IIASA, DOE), 1980s, Startup of the U.N IPCC, Mission of the IPCC, The Framework Convention on Climate Change, The Kyoto Protocol to the Framework Convention, Earth Summit, Montreal Protocol. Policy Analyses, Internationally Adopted Emissions Restrictions.

Module V

Climate Change Adaptation & Mitigation Measures: Adaptation to climate change in the fields of Ecosystems and biodiversity - Agriculture and food security, land use, forestry, human health, water supply, sanitation and infrastructure. Hazards due to climate change

and Mitigation Measures: Extreme weather events. Mitigation measures in sectors vital to humanity (food, water, health): Brief explanation of - Carbon dioxide capture and storage (CCS), Bio-energy crops, Energy efficiency in buildings.

Text Books

- Mark Masli, Climate Change: A Very Short Introduction, Oxford University Press, 2014.
- Jan C van Dam, Impacts of Climate Change and Climate Variability on Hydrological Regimes, Cambridge University Press, UK, 2003.
- Trenberth, K.E. (Editor), 1992: *Climate System Modeling*, Cambridge University Press, Cambridge, U.K.

References

- IPCC second assessment report - Working Group I Report, The Science of climate change, 1995.
- IPCC fourth assessment report - The AR4 synthesis report, 2007
- IPCC fourth assessment report - Working Group I Report, The physical Science Basis, 2007.
- IPCC fourth assessment report - Working Group II Report, Impacts, Adaptation and Vulnerability, 2007.
- IPCC fourth assessment report - Working Group III Report Mitigation of Climate change, 2007
- IPCC fifth assessment report - The AR5 synthesis report, 2014

Course Code: CET 286
Climate Change and Hazard Mitigation
Course content and Schedule of Lecture (sample)

Module	Topic	Course outcome addressed	No of Hours
Module I (9 Hours)			
1.1	Introduction to Earth’s Climate System: Basic concepts	CO1	1
1.2	Radiation, Albedo, Emissivity,	CO1	1
1.3	Scales of motion, large-scale motion	CO1	1
1.4	General circulation, troposphere-stratosphere transport	CO1	1
1.5	Atmospheric structure and thermodynamics	CO1	1
1.6	Pressure, density, composition	CO1	1

1.7	Temperature structure, water in the atmosphere	CO1	1
1.8	Atmospheric photochemistry	CO1	1
1.9	Chemical kinetics	CO1	1
Module II (9 Hours)			
2.1	Hurricanes and Global warming: Global Ocean Circulation	CO2	1
2.2	El Nino and its effects - Paleo- indicators of climate	CO2	1
2.3	The Nature of Storms—cyclones, tornadoes and hurricanes	CO2	1
2.4	Greenhouse effect-greenhouse gases-sources of emission	CO2	1
2.5	The Role of Carbon Dioxide, The Earth's Carbon Reservoirs	CO2	1
2.6	Carbon Cycling-Climate and Weather Global warming potential	CO2	1
2.7	Effects of Global warming	CO2	1
2.8	Effects of Global warming	CO2	1
2.9	Gandhian ideas on global warming.	CO2	1

Module III (9 Hours)			
3.1	Climate data and Models; Equations of atmospheric fluid mechanics, energy equation, turbulence	CO5	1
3.2	Mixing length models	CO5	1
3.3	Atmospheric chemical transport	CO5	1
3.4	General circulation models	CO5	1
3.5	Analyses of climate data	CO5	1
3.6	Climate projections and their uncertainties	CO5	1
3.7	Impacts of climate change on Surface temperature, Precipitation	CO5	1
3.8	Impacts of climate change on Ocean pH, Sea-level and Arctic sea-ice extent	CO5	1

3.9	Impacts of climate change on Ocean pH, Sea-level and Arctic sea-ice extent	CO5	1
Module IV (9 Hours)			
4.1	International initiatives to address the climate change challenges	CO4	1
4.2	History of Earth's climate – 1970s (IIASA, DOE), 1980s	CO4	1
4.3	Startup of the U.N IPCC, Mission of the IPCC	CO4	1
4.4	The Framework Convention on Climate Change	CO4	1
4.5	The Kyoto Protocol to the Framework Convention	CO4	1
4.6	Earth Summit	CO4	1
4.7	Montreal Protocol	CO4	1
4.8	Policy Analyses	CO4	1
4.9	Internationally Adopted Emissions Restrictions	CO4	1

Module V (9 Hours)			
5.1	Climate Change Adaptation & Mitigation Measures	CO3	1
5.2	Adaptation to climate change in the fields of Ecosystems and biodiversity	CO3	1
5.3	Agriculture and food security, land use, forestry, human health	CO3	1
5.4	Water supply, sanitation and infrastructure	CO3	1
5.5	Hazards due to climate change and Mitigation Measures: Extreme weather events	CO3	1
5.6	Mitigation measures in sectors vital to humanity (food, water, health)	CO3	1
5.7	Carbon dioxide capture and storage (CCS)	CO3	1
5.8	Bio-energy crops, Energy efficiency in buildings.	CO3	1
5.9	Energy efficiency in buildings.	CO3	1

AM JABDUL KALAM
TECHNOLOGICAL
UNIVERSITY

SEMESTER -4

HONOURS



CET292	COURSE NAME ADVANCED MECHANICS OF SOLIDS	CATEGORY	L	T	P	CREDIT
		VAC	3	1	0	4

Preamble: Objective of this course is to expose the students to the advanced concepts of mechanics of materials and enhance their problem-solving skills. The course aims to understand the stresses and strains in 2D and 3D solid bodies. It introduces students to the elements of theories of elasticity, failure and failure criteria. Students will be able to understand concepts, principles and governing equations in dealing with elastic solids. After this course students will be in a position to find mechanical behaviour of elastic materials by determining the stress, strains produced by the application of load.

Prerequisite: Mechanics of Solids

Course Outcomes:

Course Outcome	Description of Course Outcome	Prescribed learning level
CO 1	To explain the material properties of solids and the state of stress and strain developed in solids due to applied loads.	Remembering, Understanding & Applying
CO 2	To illustrate the different failure theories and apply the apt failure criteria to find out the Factor of Safety against structural failure.	Applying & Analysing
CO 3	To predict the structural response of standard cross sections of isotropic materials due to applied torsion.	Applying & Analysing

Mapping of course outcomes with program outcomes (Minimum requirement)

	PO 1	PO 2	PO 3	PO 4	PO 5	PO 6	PO 7	PO 8	PO 9	PO 10	PO 11	PO 12
CO 1	2	2	-	-	-	-	-	-	-	-	-	-
CO 2	3	3	-	-	-	-	-	-	-	-	-	-
CO 3	3	3	-	-	-	-	-	-	-	-	-	-

Assessment Pattern

Bloom's Category	Continuous Assessment Tests		End Semester Examination
	1	2	
Remember	10	10	15
Understand	10	10	15
Apply	15	15	35
Analyse	15	15	35
Evaluate			
Create			

Mark distribution

Total Marks	CIE	ESE	ESE Duration
150	50	100	3 hours

Continuous Internal Evaluation Pattern:

Attendance	: 10 marks
Continuous Assessment Test (2 numbers)	: 25 marks
Assignment/Quiz/Course project	: 15 marks

End Semester Examination Pattern: There will be two parts; Part A and Part B. Part A contain 10 questions with 2 questions from each module, having 3 marks for each question. Students should answer all questions. Part B contains 2 questions from each module of which student should answer any one. Each question carries 14 marks and can have maximum 2 sub-divisions.

Course Level Assessment Questions**Part A**

Course Outcome 1 (CO1): (Two questions each from module 1 to module 3 to meet the course objective 1: To understand the material properties of solids and the state of stress and strain developed in solids due to applied loads.)

1. Explain stress invariants
2. Explain Stress space
3. Explain the transformation of strain
4. Explain transformation of stress
5. List the differential equations of equilibrium for three dimensional stress state.
6. State the assumptions in classical linear elasticity
7. Differentiate between principal stress and principal strain
8. List the six compatibility equations for a three dimensional system.
9. Distinguish between rectangular strain rosette and equiangular strain rosette.
10. Differentiate between stress tensor and strain tensor
12. Explain octahedral stresses & strain

Course Outcome 2 (CO2) (Two questions from module 4 to meet the course objective 2: To understand the different failure theories and apply the apt failure criteria to find the Factor of Safety.)

1. Discuss the failure criteria for ductile materials
2. Discuss the failure criteria for brittle materials
3. Explain Palm miner rule
4. Discuss the failure due to stress reversal
5. Explain SN Curve
6. Explain stress concentration factor

Course Outcome 3 (CO3) (Two questions from module 5 to meet the course objective 3: To predict the structural response of standard cross sections of isotropic materials due to applied torsion.)

1. Discuss the use of St Venants semi inverse method
2. Explain Prandtl’s membrane analogy

Part B

All the questions under this section shall assess the learning levels corresponding to the course outcomes listed below.

CO 1	To understand the material properties of solids and the state of stress and strain developed in solids due to applied loads.
CO 2	To learn the different failure theories and apply the apt failure criteria to find the Factor of Safety against structural failure.
CO 3	To predict the structural response of standard cross sections of isotropic materials due to applied torsion.

1. The state of strain at a point in an isotropic material is given by strain tensor.

$$\begin{bmatrix} 0.002 & 0 & -0.002 \\ 0 & -0.004 & 0.0006 \\ -0.002 & 0.0006 & 0 \end{bmatrix}$$

Determine stress tensor at this point. Take E = 200 GPa. Poisson’s ratio = 0.3.

Course outcome identifier	Description of course outcome	Learning level assessed	Marks allocated
CO 1	To explain the material properties of solids and the state of stress and strain developed in solids due to applied loads.	Remembering – (Relation between Lamé’s Constants and E & Poisson’s ratio) (D matrix for Isotropic Material)	4
		Understanding- (Constitutive Stress – strain Relationship)	2
		Analysing- (Computation of stress from strain with application of Constitutive stress strain relationship)	6
		Applying- (Formation of Stress tensor from stress components)	2
Total			14

2. A low carbon steel shaft is designed to have a diameter of 25 mm. It is to be subjected to an axial load $P = 20 \text{ kN}$, a moment $M = 130 \text{ N m}$, and a torque $T = 220 \text{ Nm}$. If the yield point for the steel is 260 MPa, determine the factor of safety used in the design of the shaft based on the a) Tresca criterion of failure b) Von mises criterion of failure assuming that failure occurs at initiation of yielding.

Course outcome identifier	Description of course outcome	Learning level assessed	Marks allocated
CO 1	To explain the material properties of solids and the state of stress and strain developed in solids due to applied loads.	Analysing – (Computation of state of stress from loading situation)	6
CO 2	To illustrate the different failure theories and apply the apt failure criteria to find the Factor of Safety against structural failure.	Remembering – (Formulae for the Tresca & Von mises Criteria)	4
		Applying – Computation of Factor of Safety	4
Total			14

3. A square shaft has 42.0 mm sides and has the same cross sectional area as shafts having circular and equilateral triangular cross sections. If each shaft is subjected to a torque of 1kNm, Determine the maximum shearing stress for each of the three shafts.

Course outcome identifier	Description of course outcome	Learning level assessed	Marks allocated
CO 3	To predict the structural response of standard cross sections of isotropic materials due to applied torsion.	Understanding – (Knowledge regarding Saint Venant's Semi Inverse Method)	4
		Applying-(Use of Stress Function)	2
		Remembering- (Relation between maximum shear stress with applied Torsion and the geometric parameters	4
		Applying- (Use of appropriate Equation)	4
Total			14

Model Question Paper CET292 - Advanced Mechanics of Solids			
Qn No	Questions	Marks	Course Outcome (CO) Assessed
Part A (Answer all questions; each question carry 3 marks)			
1	Explain transformation of stress	3	1
2	Differentiate between spherical and Deviatorial stress tensor	3	1
3	Explain strain invariants	3	1
4	Distinguish between rectangular strain rosette and equiangular strain rosette	3	1
5	List the six compatibility equations for a three dimensional system	3	1
6	List out the differential equations of equilibrium for three dimensional stress state.	3	1
7	Discuss the failure criteria for ductile materials	3	2
8	Explain stress concentration factor	3	2
9	Discuss the use of St Venants semi inverse method	3	3
10	Explain Prandtl's membrane analogy	3	3
Part B (Answer one full question from each module, each question carry 14 marks)			
Module I			
11(a)	Derive the expression for the stress on arbitrarily plane whose unit normal vector is defined by $li+mj+nk$ for a rectangular coordinate system with x,y and z as reference axes.	6	1
11 (b)	Find the expression for the Normal stress and Shearing stress on a new coordinate system with X,Y and Z as the reference axes. X axis is defined by $l_1i +m_1j+n_1k$, Y axis is defined by $l_2i +m_2j+n_2k$ and Z axis is defined by $l_3i +m_3j+n_3k$	8	1
OR			
12 (a)	A rectangular bar of metal of cross section 20 mm x 35 mm is subjected to an axial tensile force of 180 kN. Calculate the normal, shear and resultant stresses on a plane whose normal has the following direction cosines $l=m=n=1/\sqrt{3}$	7	1
12(b)	The state of stress at a point is given by the following array of terms	7	1

	$\begin{bmatrix} 3 & 6 & 3 \\ 6 & 6 & 2 \\ 3 & 2 & 9 \end{bmatrix}$ MPa Determine the principal stresses and the principal directions. Find out the stress invariants in principal plane and show that it remains unchanged.		
Module II			
13 (a)	By means of strain rosette, the following strains were recorded during the test on a structural member. $\epsilon_0 = 950$ micrometres/m, $\epsilon_{45} = -110$ micrometres/m, $\epsilon_{90} = 110$ micrometres/m. Determine the magnitude and directions of principal strains.	7	1
13(b)	If the displacement field in a body is specified as $u = (x^2+4) 10^{-3}$, $v = 5y^2z * 10^{-3}$ and $w = (x + 2z) 10^{-3}$. Determine the strain tensor at a point whose coordinates are (3,2,3)	7	1
OR			
14	The strain components at a point with respect to xyz co-ordinate system are $\epsilon_x = 0.15$, $\epsilon_y = 0.16$, $\epsilon_z = 0.35$, $\gamma_{xy} = \gamma_{yz} = \gamma_{xz} = 0.170$. If the coordinate axes are rotated about the z-axis through 45° in the anticlockwise direction, determine the new strain components.	14	1
Module III			
15	The state of strain at a point is given by strain tensor. $\begin{bmatrix} 0.002 & 0 & -0.002 \\ 0 & -0.004 & 0.0006 \\ -0.002 & 0.0006 & 0 \end{bmatrix}$ Determine stress tensor at this point. Take $E = 200$ GPa. Poisson's ratio = 0.3.	14	1
OR			
16(a)	Under what conditions are the following expressions for the components of strain at a point compatible? $\epsilon_x = 2axy^2 + by^2 + 2cxy$, $\epsilon_y = ax^2 + bx$, $\gamma_{xy} = \alpha x^2 + \beta xy + ax^2 + \eta y$	7	1
16(b)	The stress components at a point in a body are given by $\sigma_x = 5xy^2z + 2x$, $\sigma_y = 3xyz + 3y$, $\sigma_z = x^2y + y^2z$, $\tau_{xy} = 0$, $\tau_{yz} = \tau_{xz} = 2xy^2z + 2xy$ Determine whether these components of stress satisfy the equilibrium equations or not at the point (1,-1,2). If not then determine the suitable body force required at this point so that these stress components are under equilibrium.	7	1

Module IV			
17	Represent all the yield criteria for failure graphically in the 2D stress space with rectangular axes σ_1 and σ_2 for the material steel. Assume the yield point of steel as 350 MPa and poisson ratio as 0.25. Mention the equation also in the graph.	14	2
OR			
18	A closed end thin-walled cylindrical of a metal with yield point = 700 MPa has an inside diameter of 20mm. The cylinder is subjected to an internal pressure of 22 MPa and an axial load of 50 kN. Determine the torque that can be applied to the cylinder if the factor of safety for design is 1.80. Check whether the material is safe under Von mises criteria.	14	2
Module V			
19	A hollow thin-wall brass tube has an equilateral triangular cross section. The mean length of each side of the triangle is 40.0mm. The wall thickness is 4.00mm. Determine the torque and unit angle of twist for an average shearing stress of 20.0 MPa. ($G = 31.1 \text{ GPa}$)	14	3
OR			
20	A torsion member has an elliptical cross section with major and minor dimensions of 100 mm and 70 mm, respectively. The yield stress of the material is 350 MPa. Determine the maximum torque that can be applied to the torsion member based on a factor of safety 1.8 using maximum shearing stress criterion of failure.	14	3

Syllabus**Module 1 Stress in 3-D**

Definition of stress at a point, Stress Notation, Stress Tensor, Normal stress and Shearing Stress on an oblique plane, Transformation of stress, Principal Stress, Stress Invariants, Octahedral Stress, Mean and Deviator Stress, Plane stress, Mohr's Circle in Two Dimensions, Differential Equations of motion of a deformable body.

Module 2 Strain in 3-D

Types of Strain, Deformation of a deformable body, Strain Tensor, Strain Transformation, Spherical and Deviatorial Strain Tensor, Principal Strains, Strain Invariants, Octahedral Strains, Mohr Circle for strain, Equations of Compatibility for Strain, Strain Rosettes

Module 3 Elements of Theory of Elasticity

Strain Energy Density, Complementary Internal Energy Density, Elasticity and Strain Energy Density, Elasticity and Complementary Internal Energy Density, Generalized Hooke's Law, Anisotropic Elasticity, Isotropic Elasticity, Displacements-strains and compatibility-equilibrium equations and boundary conditions

Module 4 Failure and Failure criteria

Modes of failure, yield failure criteria, Maximum Principal Stress Criteria, Maximum Shear stress criteria, Maximum Strain Criteria, Maximum Strain Energy Density Criteria, Von Mises Criteria, fatigue, Stress Concentration Factor, Palm Miner Rule, SN Curve

Module 5 Torsion

Torsion of a cylindrical bar of circular cross section- St.Venant's semi inverse method-stress function approach-elliptical, equilateral triangle & narrow rectangular cross sections - Prandtl's membrane analogy-Hollow thin wall torsion members

Text Books

1. A.P. Boresi and O.M. Sidebottom, Advanced Mechanics of Materials, 4th edition, John Wiley & Sons, 1985
2. R.D. Cook and W.C. Young, Advanced Mechanics of Materials, 2nd edition, Prentice Hall Intl, Inc. 1999
3. Srinath L.S., Advanced Mechanics of Solids, Tata McGraw Hill, 3e, 2009

Reference Books

1. S P Timoshenko, Strength of Materials Vol II, CBS Publishers, 2002
2. Shames, E.H., Mechanics of Deformable solids, Prentice Hall Inc., 1964
3. Timoshenko S.P and Goodier J.N, Theory of elasticity, McGraw Hill, 3e, 1970

Lecture Plan – Advanced Mechanics of Solids

<i>Module</i>	<i>Topic</i>	<i>Course outcomes addressed</i>	<i>No. of Lectures</i>
1	Module I : Total lecture hours : 9		
1.1	Definition of stress at a point, Stress Notation, Stress Tensor, Mean and Deviator Stress	CO1	Lecture 1
1.2	Definition of Plane, Normal Stress on an oblique plane	CO1	Lecture 2
1.3	Shearing Stress on an oblique plane	CO1	Lecture 3
1.4	Transformation of stress, Principal Stress,	CO1	Lecture 4
1.5	Stress Invariants & Octahedral Stress.	CO1	Lecture 5
1.6	Plane stress & Mohr's Circle in Two Dimensions	CO1	Lecture 6
1.7	Differential Equations of motion of a deformable body	CO1	Lecture 7
2	Module II : Total lecture hours : 9		
2.1	Types of Strain & Deformation of a deformable body	CO2	Lecture 1
2.2	Strain Tensor & Strain Transformation,	CO2	Lecture 2
2.3	Spherical and Deviatorial Strain Tensor	CO2	Lecture 3
2.4	Principal Strains & Strain Invariants	CO2	Lecture 4
2.5	Octahedral Strains & Mohr Circle for strain	CO2	Lecture 5
2.6	Equations of Compatibility for Strain	CO2	Lecture 6
2.7	Strain Rosettes	CO2	Lecture 7
3	Module III : Total lecture hours : 9		
3.1	Strain Energy Density & Complementary Internal Energy Density	CO3	Lecture 1
3.2	Elasticity and Strain Energy Density	CO3	Lecture 2
3.3	Elasticity and Complementary Internal Energy Density	CO3	Lecture 3
3.4	Generalized Hooke's Law	CO3	Lecture 4
3.5	Anisotropic Elasticity & Isotropic Elasticity	CO3	Lecture 5
3.6	Displacements-strains and compatibility	CO3	Lecture 6
3.7	Equilibrium equations and boundary conditions	CO3	Lecture 7

4	Module IV : Total lecture hours : 9		
4.1	Modes of failure, yield failure criteria,	CO4	Lecture 1
4.2	Maximum Principal Stress Criteria & Maximum Shear stress criteria	CO4	Lecture 2
4.3	Maximum Strain Criteria	CO4	Lecture 3
4.4	Maximum Strain Energy Density Criteria	CO4	Lecture 4
4.5	Von Mises Criteria	CO4	Lecture 5
4.6	fatigue, Stress Concentration Factor	CO4	Lecture 6
4.7	Palm Miner Rule & SN Curve	CO4	Lecture 7
5	Module V : Total lecture hours : 9		
5.1	Torsion of a cylindrical bar of circular cross section	CO3	Lecture 1
5.2	St. Venant's semi inverse method	CO3	Lecture 2
5.3	Stress function approach- elliptical	CO3	Lecture 3
5.4	Torsion- Equilateral triangle cross sections	CO3	Lecture 4
5.5	Torsion- narrow rectangular cross sections	CO3	Lecture 5
5.6	Prandtl's membrane analogy	CO3	Lecture 6
5.7	Hollow thin wall torsion members	CO3	Lecture 7

CET 294	PAVEMENT CONSTRUCTION AND MANAGEMENT	CATEGORY	L	T	P	CREDIT	YEAR OF INTRODUCTION
		VAC	4	0	0	4	2019

Preamble

Objective of the course is to introduce the principles and practice of Highway construction and infrastructure asset management

Prerequisite: NIL

Course Outcomes:

	Description
CO No.	At the end of the course, students will be able to:
CO 1	To understand the characterization of materials used for pavement construction
CO 2	To carry out mix design of various bituminous mixes
CO 3	To study construction practices of flexible pavement and equipment used
CO 4	To understand the construction practices and reinforcement design of rigid pavement
CO 5	To study the fundamentals of pavement evaluation and pavement management system

Mapping of course outcomes with program outcomes

	PO1	PO2	PO3	PO4	PO5	PO6	PO7	PO8	PO9	PO10	PO11	PO12	PSO1	PSO2
CO 1	3	3	3	1		1	3	1		2		1	2	3
CO 2	3	1	3	1		1	1	1		1		1	2	2
CO 3	3	2	2	1					1	2		2	2	3
CO 4	2						2	1				2	2	3
CO 5	3	3	3			3		2					2	3

Assessment Pattern

Bloom's Category	Continuous Assessment		End Semester Examination (marks)
	Test 1 Marks	Test 2 Marks	
Remember	10	10	30
Understand	10	10	30
Apply	5	5	20
Analyse	5	5	20
Evaluate			
Create			

Mark Distribution

Total Marks	CIE (Marks)	ESE (Marks)	ESE Duration
150	50	100	3 hours

Continuous Internal Evaluation Pattern:

Attendance	: 10 marks
Continuous Assessment Test (2 numbers)	: 25 marks
Assignment/Quiz/Course Project	: 15 marks

End Semester Examination Pattern:

The question consists of two parts- Part A and Part B. Part A consists of 10 questions with 3 marks for each (two questions from each module). Part B consists of two questions from each module, out of which one has to be answered. Each question carries 14 marks and can have maximum 2 subdivisions.

Sample Course Level Assessment Questions:

Course Outcome 1 (CO1): Explain the desirable properties of aggregates to be used in different types of pavement construction?

Course Outcome 2 (CO2): A bitumen mixture contains 60% coarse aggregate; 35% fine aggregate; 5% asphalt (by weight). Determine unit weight of mixture after compaction with 7% air voids? $G_{CA}=2.72$, $G_{FA}=2.66$, $G_A=1.0$

Course Outcome 3 (CO3): Explain the method of preparation of mix and construction steps for laying bituminous macadam base course?

Course Outcome 4 (CO4): With neat sketch explain the joints in cement concrete pavements?

Course Outcome 5 (CO5): Compare project level and network level pavement management systems.

Syllabus

Module 1

Pavement: functions and characteristics- Types of pavement: flexible pavement, rigid pavement, comparison- Different layers of flexible and rigid pavement

Pavement materials: characterization of sub grade soil, soil classification system, properties of road aggregate, principles and methods of gradation of soil aggregate mixes, characteristics and uses of bitumen, emulsion cutback and modified bitumen.

Module 2

Bituminous pavement types: penetration layer system and premixed aggregate- specification of materials,

Mix design: physical and volumetric properties of bituminous mix, Marshall method of mix design, Super pave mix design

Module 3

Construction of flexible pavement: functions of various layers, preparation and construction of sub grade, granular sub base (GSB), WBM, WMM, Bituminous macadam, Different types of wearing courses. specifications/ guild lines, equipment used for the construction of different layers in flexible pavement, quality control for flexible pavement construction

Module 4

Construction of cement concrete pavement: material characterization, preparation of subgrade and base, Types of joints in Rigid pavements its functions and design, presetting reinforcement in joints and PCC slab construction

Module 5

Introduction to pavement management system(PMS): concept, definition, objectives, components, general structure- data collection pavement evaluation, functional and structural evaluation, pavement deterioration models, pavement management levels: network, programme and project level- types of pavement management system, Types of Maintenance and rehabilitation activities, life cycle cost analysis of strategies, popular software

TEXT BOOKS

1. Khanna, S.K, Justo E.G, .A Veeraragavan, Highway Engineering 10th edition, Khanna Publishers.2018
2. Kadiyali, L. R., Principles of Highway Engineering, Khanna Publishers, 2001
3. Rajib B. Mallick and TaharEl-Korchi, Pavement Engineering CRC press, 2009
4. Rao G. V, Principles of Transportation and Highway Engineering, Tata McGrawHill, 1996
5. Prithvi Singh Khandhal, Bituminous Road Construction in India, PHI Learning, 2019

REFERENCES

1. Manual for construction and supervision of Bituminous works, MoRTH 2001
2. Shahin M.Y, Pavement Management for Airports, Roads and Parking lots, Chapman & Hall, 2005
3. IRC: 37-2018, Guidelines for the Design of Flexible Pavements, IRC 2018, New Delhi
4. MoRTH, IRC code for pavement evaluation, data collection

Course Content and lecture Schedule:

Sl No.	Topic	Course Outcome	No of Hours
1	Module 1		Total:10
1.1	Functions and characteristics of pavements, Types of pavement and comparison (flexible pavement, rigid pavement)	CO1	1
1.2	Different layers and properties of flexible and rigid pavement	CO1	1
1.3	characterization of sub grade soil and soil classification system	CO1	2
1.4	Properties of road aggregate, principles and methods of gradation of soil aggregate mixes	CO1	3
1.5	Characteristics and uses of bitumen, emulsion cutback and modified bitumen	CO1	3
2	Module 2		Total:8
2.1	Penetration layer system and premixed aggregate system	CO2	2
2.2	Physical and volumetric properties of bituminous mix, Marshall method of mix design, Superpave Mix design	CO2	6
3	Module 3		Total:8
3.1	Functions of various layers of flexible pavement, preparation and construction of sub grade, granular sub base (GSB), WBM, WMM, Bituminous macadam, Different types of wearing courses specifications/ guidelines	CO3	4
3.2	Equipment used for the construction of different layers in flexible pavement, quality control for flexible pavement construction	CO3	4
	Module 4		Total:6
4.1	Construction of cement concrete pavement :material characterization, preparation of subgrade and base	CO4	3
4.2	Types of joints in Rigid pavements its functions and design, presetting reinforcement in joints and PCC slab construction	CO4	3
	Module 5		Total:13
5.1	Introduction to pavement management system(PMS): concept, definition, objectives, components, general structure-data collection	CO5	3
5.2	Pavement evaluation, functional and structural evaluation, pavement deterioration models,	CO5	3
5.3	Pavement management levels: network, program and project level	CO5	2
5.4	Types of pavement management system, Types of Maintenance and rehabilitation activities	CO5	2
5.5	life cycle cost analysis of strategies, popular software	CO5	3

**APJ ABDUL KALAM TECHNOLOGICAL UNIVERSITY
THIRD SEMESTER B. TECH DEGREE EXAMINATION, MONTH & YEAR**

Course Code: CET 294

Course Name: **PAVEMENT CONSTRUCTION AND MANAGEMENT**
Model Question Paper

Marks: 100

Duration: 3 hrs

PART A

(Answer all Questions: Each question carries 3 marks)

1. What are the functions of pavement?
2. Define emulsified and cutback bitumen
3. What are the types of bitumen mixes for pavement?
4. Define VMA and VFB
5. Draw a typical cross section of a highway in cutting and show the various flexible pavement layers
6. What are the common types of equipment for compaction of soil for embankment and subgrade?
7. Draw a neat diagram showing various component layers of a CC pavement structure.
8. What are objects of providing dowel bars in CC pavement?
9. Differentiate between functional and structural evaluation of pavement.
10. What are the objectives of Pavement Management System?

(3 x 10 = 30)

PART B

(Answer one full question from each module)

11. a) Differentiate between flexible and rigid pavement
(7)
b) Explain CBR and the test procedure in the laboratory. How are the results of the test obtained and interpreted?
(7)

OR

12. a) What are the desirable properties of road aggregates? Explain aggregate impact test and shape test.
(10)

b) Explain grading of bitumen
(4)

13. a) Differentiate between dense graded and gap graded mixtures, giving one example for each
(6)

b) In a Marshall test, bituminous concrete cylinder is made whose weight is 1250 gms with the volume of 820 cc. The weights and specific gravities of various ingredients are given in the table. Determine VMA and VFB.
(8)

Type	A1	A2	A3	Flyash	Bitumen
Wt (g)	868	322	430	350	180
G	2.78	2.63	2.32	2.36	1.05

OR

14. a) Explain the Marshall method of bituminous mix design
(10)

b) In a bituminous concrete mix the theoretical specific gravity is 2.434, bulk specific gravity is 2.323, specific gravity of bitumen used is 1.05 with 4.35% weight of bitumen in the mix. Determine VMA, VFB.
(4)

15. a) Explain the construction procedure for base and sub-base courses in flexible pavement construction
(7)

b) List various excavating machinery used during highway construction. Mention the uses and limitations of each
(7)

OR

16. a) Write notes on the following types of bituminous pavement layers (i) stone matrix asphalt (ii) slurry seal (iii) micro-surfacing
(7)

b) What are the quality control tests during the construction of bituminous concrete layer? Mention the objectives of each
(7)

17. a) Write a note on importance and construction of (i) drainage layer for CC pavement (ii) dry lean concrete sub-base course (iii) separation membrane (10)

b) A rigid pavement is constructed at 28°C, peak summer temperature is 45°C, peak winter temperature is 10°C, the gap at expansion joint is 25mm, $\alpha_c=10 \times 10^{-6} / ^\circ\text{C}$. Calculate the spacing of expansion joint?

(4)

OR

18. a) What are the different materials required for the construction of a CC pavement? Mention how a concrete mix is designed for obtaining PQC.

(7)

b) Classify different types of joints in CC pavements and mention the objects of each.

(7)

19. a) Differentiate between destructive and non-destructive structural evaluation of pavement. (7)

b) Compare project level and network level pavement management system

(7)

OR

20. a) Discuss the structure (component) of a Pavement Management System (8)

b) Explain Life Cycle Cost Analysis

(6)

CET 296	GEOGRAPHICAL INFORMATION SYSTEMS	CATEGORY	L	T	P	CREDIT	Year of Introduction
		VAC	4	0	0	4	2019

Preamble: Goal of this course is to expose the students to the fundamental concepts and components of Geographical Information System (GIS). After successful completion this course, students will be able to identify the requirements for the development of GIS module for various applications.

Prerequisite: Nil

Course Outcomes: After completion of the course the student will be able:

Course outcome identifier	Description of course outcome	Prescribed learning level
CO 1	To define terms, basic concepts and operations in GIS	Remembering
CO2	To identify various data types and their characteristics.	Understanding
CO 3	To illustrate various approaches of spatial data analysis and their significance in decision making.	Applying
CO 4	To demonstrate the application of GIS and allied technologies across diverse fields.	Applying

Mapping of course outcomes with program outcomes (Minimum requirement)

	PO 1	PO 2	PO 3	PO 4	PO 5	PO 6	PO 7	PO 8	PO 9	PO 10	PO 11	PO 12
CO 1	1	-	-	-	-	-	-	-	-	-	-	-
CO 2	1	2	-	-	-	-	-	-	-	-	-	-
CO 3	2	3	2	-	2	-	-	-	-	-	-	-
CO 4	2	3	2	-	2	-	-	-	-	-	-	-
CO5												

Assessment Pattern

Bloom's Category	Continuous Assessment Tests		End Semester Examination (Marks)
	Test 1 (Marks)	Test 2 (Marks)	
Remember	7.5	7.5	30
Understand	7.5	7.5	30
Apply	10	10	40
Analyse			
Evaluate			
Create			

Mark Distribution

Total Marks	CIE (Marks)	ESE (Marks)	ESE Duration
150	50	100	3 hours

Continuous Internal Evaluation Pattern:

Attendance	: 10 marks
Continuous Assessment Test (2 numbers)	: 25 marks
Assignment/Quiz/Course Project	: 15 marks

End Semester Examination Pattern:

There will be two parts: Part A and Part B.

Part A contains 10 questions with 2 questions from each module and each question shall carry 3 marks. Students should answer all questions.

Part B contains 2 questions from each module of which student should answer any one. Each question carries 14 marks and can have maximum 2 sub-divisions

Syllabus**Module 1**

Basic concepts of GIS , History of GIS, Components of GIS-Geospatial Data, Attribute data, GIS operations, Application of GIS, Popular GIS Softwares.

Geographic Co-ordinate system, Map Projections, Commonly used Map Projections, Projected co-ordinate system, Georeferencing, Geometric Transformations.

Tutorial- Introducing any GIS software and its tools.

Module 2

Data structure -Vector Data model, Raster Data model, Types of Raster data, Data inputs to GIS platform, Metadata, Vector to Raster conversion, Digitization.

Geodatabase management, Attribute data management. Cartography and map making elements.

Tutorial exercises: Georeferencing, raster to vector conversion, assigning attribute data

Module 3

GIS Data Processing –Vector data Analysis- Buffering, Overlay-Point-in-Polygon, Line-in-polygon, Polygon-in-polygon, Distance measurement, Pattern analysis, Map manipulation, Network Analysis

Raster Data Analysis- Local operations, Neighbourhood operation, Zonal Operation, other Raster data operations.

Tutorial exercises: Digitization using available data source and creating a Map Using different map elements.

Module 4

Advanced Applications: Introduction to terrain mapping, DEM and TIN, terrain mapping techniques, Slope and aspect, WebGIS.

Data quality analysis – Sources of Error – Components of Data Quality

Tutorial exercises: working with a surface / terrain models

Module 5

Remote sensing: Definition, Basic Principles, Application of remote sensing in GIS.

Global Positioning System (GPS) - GPS Basic concepts, GPS segments-satellites & receivers, GPS applications. Application of *GPS data in GIS environment*.

Tutorial exercises: Create a small GIS module using GPS or RS data.

Text Books:

1. Chang,K , “Introduction to Geographic Information Systems”, Tata McGraw-Hill Publishing Co. Ltd, 2008
2. George Joseph, “Fundamentals of Remote Sensing”, University Press, 2003
3. Robert Laurini and Derek Thompson, “Fundamentals of Spatial Information Systems”, Academic Press, 1996.

References:

1. BurroughP, Principles of Geographical Information systems, Oxford University Press, 1998
2. Iliffe, C.J., Datums and Map Projections for Remote Sensing, GIS and Surveying, Whittles Publishing, 2006
3. Kang-tsung Chang, „Introduction to GIS“ , Tata McGraw-Hill Publishing Co. Ltd, 8e, 2016
4. Lillesand M and Kiefer W, “Remote Sensing and Image Interpretation”. John Wiley and Sons,Inc., 2000
5. Iliffe, C.J., Datums and Map Projections for Remote Sensing, GIS and Surveying, Whittles Publishing, 2006

Course Contents and Lecture Schedule:

No.	Topic	Course Outcome	No. of Hrs
1	Module 1		Total: 9
1.1	Basic concepts of GIS , History of GIS, Components of GIS- Geospatial Data, Attribute data, GIS operations, Application of GIS , Popular GIS Softwares.	CO1, CO2	3
1.2	Co-ordinate system: Geographic Co-ordinate system, Map Projections, Commonly used Map Projections, Projected co-ordinate system, Georeferencing, Geometric Transformations.	CO1, CO2	4
1.3	Tutorial- Introducing a GIS software and its tools.	CO1, CO2	2
2	Module 2		Total: 9
2.1	Data structure -Vector Data model, Raster Data model, Types of Raster data, Data inputs to GIS platform, Metadata, Vector to Raster conversion, Digitization.	CO1. CO2 CO3	4
2.2	Database management and map making: Geodatabase management, Attribute data management. Cartography and map making elements.	CO1, CO2 CO3	3
2.3	<i>Tutorial exercises: Digitization using available data source and creating a Map Using different map elements.</i>	CO2, CO3	2
3	Module 3		Total: 9
3.1	GIS Data Processing – Vector data Analysis- Buffering, Overlay- Point-in-Polygon, Line-in-polygon, Polygon-in-polygon, Distance measurement, Pattern analysis, Map manipulation, Network Analysis	CO1, CO2 CO3,CO4	4
3.2	Raster Data Analysis - Local operations, Neighbourhood operation, Zonal Operation, other Raster data operations.	CO1,CO2 CO3,CO4	3
3.3	<i>Tutorial exercises: Digitization using available data source and creating a Map Using different map elements.</i>	CO3,CO4	2
4	Module 4		Total: 9
4.1	Advanced Applications: Introduction to terrain mapping, DEM and TIN, terrain mapping techniques, Slope and aspect, WebGIS.	CO1,CO2 CO3,CO4	4
4.2	Data quality analysis – Sources of Error – Components of Data Quality	CO1,CO2 CO3,CO4	3
4.3	<i>Tutorial exercises: working with a surface / terrain models</i>		2
5	Module 5		Total: 9
5.1	Remote sensing: Definition, Basic Principles, Application of remote sensing in GIS.	CO1,CO2 CO3,CO4	3
5.2	Global Positioning System (GPS) - GPS Basic concepts, GPS segments-satellites & receivers, GPS applications. Application of GPS data in GIS environment.	CO1,CO2 CO3,CO4	4
5.3	<i>Tutorial exercises: Create a small GIS module using GPS or RS data.</i>	CO3, CO4	2

Sample Course Level Assessment Questions

CO 1	To define terms, basic concepts and operations in GIS
CO2	To identify various data types and their characteristics.
CO 3	To illustrate various approaches of spatial data analysis and their significance in decision making.
CO 4	To demonstrate the application of GIS and allied technologies across diverse fields.

CO1

1. Prepare a short account on Geodetic datum, Ellipsoid earth model and Georeferencing
2. State any two functions of a GIS module
3. Write a short note on Digital Elevation Model.

CO2

1. Compare raster data sets and vector data sets. Highlight their significance in GIS environment
2. Briefly explain raster data form in GIS.
3. Explain any two approaches for spatial data acquisition for infrastructure development process.

CO3

1. Prepare short description on (i) Positional accuracy (ii) Attribute accuracy
2. Explain any two types of errors associated with spatial data analysis.
3. Explain different type of image resolutions and establish their importance in the GIS analysis.

CO4

1. Briefly illustrate the utility of GIS module in tracking and navigation.
2. Explain how GPS is used in the map preparation and locating ground features.
3. Highlight the advantages offered by remote sensing operation in the developmental decision making.

Model Question Paper

QP CODE:

Reg No.: _____

Name: _____

ABDUL KALAM TECHNOLOGICAL UNIVERSITY

FOURTH SEMESTER B.TECH DEGREE EXAMINATION, MONTH & YEAR

Course Code: CET 296

Course Name : GEOGRAPHICAL INFORMATION SYSTEMS

Max. Marks: 100

Duration: 3 hours

PART A

(Answer all questions)

(10 × 3 = 30)

1. Illustrate any two spatial data collection methods adopted for preparation of GIS.
2. What are the different components in GIS?
3. Define (i) Vector data (ii) Raster data
4. Establish the role of shapefiles in GIS.
5. Distinguish between pattern analysis and network analysis.
6. Demonstrate the significance of buffering in GIS
7. State any two sources of data error.
8. Define the terms : Slope and Aspect
9. List any two applications of GIS in combination with GPS.
10. Illustrate the role of atomic clock in GPS.

PART B

- 11 (i) Explain different techniques of remote sensing used for data collection
(ii) What is the role of georeferencing in GIS operation

(7 + 7)

or

- 12 (i) illustrate any three applications of GIS
(ii) Compare cylindrical projections and conical projections

(6+ 8)

- 13 (i) What are the different models adopted to represent vector data?
(iii) Highlight the role of digitisation in map preparation

(7 + 7)

or

14 (i) List the steps involved in the preparation of a digital map.

(ii) Compare continuous raster and discrete raster

(6+ 8)

15. (i) Prepare a short account on (a) Pattern analysis (b) Network analysis.

(ii) Illustrate any two raster data operations

(7 + 7)

or

16. (i) Explain any three factors that influences the choice of weights in the analysis of networks.

(ii) What are the different zonal operations suggested in the neighborhood analysis of raster data ?

(6 + 8)

17. (i) Explain the importance of using DEM for various engineering analysis.

(ii) Prepare different sources of error in a GIS operation.

(7 + 7)

or

18 (i) State any two approaches to reduce the error in GPS data transfer

(ii) Prepare a brief description of GIS data standard.

(7+7)

19. (i) Differentiate between ground based remote sensing and satellite based remote sensing ?

(ii) Justify - integration of GIS and GPS technologies could solve different problems faced in logistic operations.

(6 + 8)

or

20. (i) Explain different components of a GPS segment.

(ii) Illustrate the utility of remote sensing data in GIS module using any two cases.

(7+ 7)

AM JABAR
ALLAH ABDUL KALAM
TECHNOLOGICAL
UNIVERSITY

SEMESTER -3

COMMON COURSES S3 & S4



CODE MCN201	SUSTAINABLE ENGINEERING	CATEGORY	L	T	P	CREDIT
			2	0	0	NIL

Preamble: Objective of this course is to inculcate in students an awareness of environmental issues and the global initiatives towards attaining sustainability. The student should realize the potential of technology in bringing in sustainable practices.

Prerequisite: NIL

Course Outcomes: After the completion of the course the student will be able to

CO 1	Understand the relevance and the concept of sustainability and the global initiatives in this direction
CO 2	Explain the different types of environmental pollution problems and their sustainable solutions
CO 3	Discuss the environmental regulations and standards
CO 4	Outline the concepts related to conventional and non-conventional energy
CO 5	Demonstrate the broad perspective of sustainable practices by utilizing engineering knowledge and principles

Mapping of course outcomes with program outcomes

	PO 1	PO 2	PO 3	PO 4	PO 5	PO 6	PO 7	PO 8	PO 9	PO 10	PO 11	PO 12
CO 1						2	3					2
CO 2						2	3					2
CO 3						2	3					2
CO 4						2	3					2
CO 5						2	3					2

Assessment Pattern

Mark distribution

Bloom's Category	Continuous Assessment Tests		End Semester Examination
	1	2	
Remember	20	20	40
Understand	20	20	40
Apply	10	10	20
Analyse			
Evaluate			
Create			

Continuous Internal Evaluation Pattern:

Attendance : 10 marks
 Continuous Assessment Test (2 numbers) : 25 marks
 Assignment/Quiz/Course project : 15 marks

End Semester Examination Pattern: There will be two parts; Part A and Part B. Part A contain 10 questions with 2 questions from each module, having 3 marks for each question. Students should answer all questions. Part B contains 2 questions from each module of which student should answer any one. Each question can have maximum 2 sub-divisions and carry 14 marks.

Total Marks	CIE	ESE	ESE Duration
150	50	100	3 hours

Course Level Assessment Questions

Course Outcome 1 (CO1): Understand the relevance and the concept of sustainability and the global initiatives in this direction

1. Explain with an example a technology that has contributed positively to sustainable development.
2. Write a note on Millennium Development Goals.

Course Outcome 2 (CO2): Explain the different types of environmental pollution problems and their sustainable solutions

1. Explain the 3R concept in solid waste management?
2. Write a note on any one environmental pollution problem and suggest a sustainable solution.
3. In the absence of green house effect the surface temperature of earth would not have been suitable for survival of life on earth. Comment on this statement.

Course Outcome 3(CO3): Discuss the environmental regulations and standards

1. Illustrate Life Cycle Analysis with an example of your choice.
2. “Nature is the most successful designer and the most brilliant engineer that has ever evolved”. Discuss.

Course Outcome 4 (CO4): Outline the concepts related to conventional and non-conventional energy

1. Suggest a sustainable system to generate hot water in a residential building in tropical climate.
2. Enumerate the impacts of biomass energy on the environment.

Course Outcome 5 (CO5): Demonstrate the broad perspective of sustainable practices by utilizing engineering knowledge and principles

1. Suggest suitable measures to make the conveyance facilities used by your institution sustainable.

Model Question paper

Part A

(Answer all questions. Each question carries 3 marks each)

1. Define sustainable development.
2. Write a short note on Millennium Development Goals.
3. Describe carbon credit.
4. Give an account of climate change and its effect on environment.
5. Describe biomimicry? Give two examples.
6. Explain the basic concept of Life Cycle Assessment.
7. Name three renewable energy sources.

8. Mention some of the disadvantages of wind energy.
9. Enlist some of the features of sustainable habitat.
10. Explain green engineering.

Part B

(Answer one question from each module. Each question carries 14 marks)

11. Discuss the evolution of the concept of sustainability. Comment on its relevance in the modern world.
OR
12. Explain Clean Development Mechanism.
13. Explain the common sources of water pollution and its harmful effects.
OR
14. Give an account of solid waste management in cities.
15. Explain the different steps involved in the conduct of Environmental Impact Assessment.
OR
16. Suggest some methods to create public awareness on environmental issues.
17. Comment on the statement, "Almost all energy that man uses comes from the Sun".
OR
18. Write notes on:
 - a. Land degradation due to water logging.
 - b. Over exploitation of water.
19. Discuss the elements related to sustainable urbanisation.
OR
20. Discuss any three methods by which you can increase energy efficiency in buildings.

Syllabus

Sustainability- need and concept, technology and sustainable development-Natural resources and their pollution, Carbon credits, Zero waste concept. Life Cycle Analysis, Environmental Impact Assessment studies, Sustainable habitat, Green buildings, green materials, Energy, Conventional and renewable sources, Sustainable urbanization, Industrial Ecology.

Module 1

Sustainability: Introduction, concept, evolution of the concept; Social, environmental and economic sustainability concepts; Sustainable development, Nexus between Technology and Sustainable development; Millennium Development Goals (MDGs) and Sustainable Development Goals (SDGs), Clean Development Mechanism (CDM).

Module 2

Environmental Pollution: Air Pollution and its effects, Water pollution and its sources, Zero waste concept and 3 R concepts in solid waste management; Greenhouse effect, Global warming, Climate change, Ozone layer depletion, Carbon credits, carbon trading and carbon foot print, legal provisions for environmental protection.

Module 3

Environmental management standards: ISO 14001:2015 frame work and benefits, Scope and goal of Life Cycle Analysis (LCA), Circular economy, Bio-mimicking, Environment Impact Assessment (EIA), Industrial ecology and industrial symbiosis.

Module 4

Resources and its utilisation: Basic concepts of Conventional and non-conventional energy, General idea about solar energy, Fuel cells, Wind energy, Small hydro plants, bio-fuels, Energy derived from oceans and Geothermal energy.

Module 5

Sustainability practices: Basic concept of sustainable habitat, Methods for increasing energy efficiency in buildings, Green Engineering, Sustainable Urbanisation, Sustainable cities, Sustainable transport.

Reference Books

1. Allen, D. T. and Shonnard, D. R., Sustainability Engineering: Concepts, Design and Case Studies, Prentice Hall.
2. Bradley. A.S; Adebayo,A.O., Maria, P. Engineering applications in sustainable design and development, Cengage learning
3. Environment Impact Assessment Guidelines, Notification of Government of India, 2006
4. Mackenthun, K.M., Basic Concepts in Environmental Management, Lewis Publication, London, 1998
5. ECBC Code 2007, Bureau of Energy Efficiency, New Delhi Bureau of Energy Efficiency Publications-Rating System, TERI Publications - GRIHA Rating System
6. Ni bin Chang, Systems Analysis for Sustainable Engineering: Theory and Applications, McGraw-Hill Professional.
7. Twidell, J. W. and Weir, A. D., Renewable Energy Resources, English Language Book Society (ELBS).
8. Purohit, S. S., Green Technology - An approach for sustainable environment, Agrobios Publication

Course Contents and Lecture Schedule

No	Topic	No. of Lectures
1	Sustainability	
1.1	Introduction, concept, evolution of the concept	1
1.2	Social, environmental and economic sustainability concepts	1
1.3	Sustainable development, Nexus between Technology and Sustainable development	1
1.4	Millennium Development Goals (MDGs) and Sustainable Development Goals (SDGs)	1
1.5	Clean Development Mechanism (CDM)	1
2	Environmental Pollution	
2.1	Air Pollution and its effects	1
2.2	Water pollution and its sources	1
2.3	Zero waste concept and 3 R concepts in solid waste management	1
2.4	Greenhouse effect, Global warming, Climate change, Ozone layer depletion	1
2.5	Carbon credits, carbon trading and carbon foot print.	1
2.6	Legal provisions for environmental protection.	1
3	Environmental management standards	
3.1	Environmental management standards	1
3.2	ISO 14001:2015 frame work and benefits	1
3.3	Scope and Goal of Life Cycle Analysis (LCA)	1
3.4	Circular economy, Bio-mimicking	1
3.5	Environment Impact Assessment (EIA)	1
3.6	Industrial Ecology, Industrial Symbiosis	1
4	Resources and its utilisation	
4.1	Basic concepts of Conventional and non-conventional energy	1
4.2	General idea about solar energy, Fuel cells	1
4.3	Wind energy, Small hydro plants, bio-fuels	1
4.4	Energy derived from oceans and Geothermal energy	1
5	Sustainability Practices	
5.1	Basic concept of sustainable habitat	1
5.2	Methods for increasing energy efficiency of buildings	1
5.3	Green Engineering	1
5.4	Sustainable Urbanisation, Sustainable cities, Sustainable transport	1

CODE	COURSE NAME	CATEGORY	L	T	P	CREDIT
				2	0	0
EST 200	DESIGN AND ENGINEERING					

Preamble:

The purpose of this course is to

- i) introduce the undergraduate engineering students the fundamental principles of design engineering,
- ii) make them understand the steps involved in the design process and
- iii) familiarize them with the basic tools used and approaches in design.

Students are expected to apply design thinking in learning as well as while practicing engineering, which is very important and relevant for today. Case studies from various practical situations will help the students realize that design is not only concerned about the function but also many other factors like customer requirements, economics, reliability, etc. along with a variety of life cycle issues.

The course will help students to consider aesthetics, ergonomics and sustainability factors in designs and also to practice professional ethics while designing.

Prerequisite:

Nil. The course will be generic to all engineering disciplines and will not require specialized preparation or prerequisites in any of the individual engineering disciplines.

Course Outcomes:

After the completion of the course the student will be able to

CO 1	Explain the different concepts and principles involved in design engineering.
CO 2	Apply design thinking while learning and practicing engineering.
CO 3	Develop innovative, reliable, sustainable and economically viable designs incorporating knowledge in engineering.

Mapping of course outcomes with program outcomes

	PO 1	PO 2	PO 3	PO 4	PO 5	PO 6	PO 7	PO 8	PO 9	PO 10	PO 11	PO 12
CO 1	2	1					1			1		
CO 2		2				1		1				2
CO 3			2			1	1		2	2		1

Assessment Pattern**Continuous Internal Evaluation (CIE) Pattern:**

Attendance	: 10 marks
Continuous Assessment Test (2 numbers)	: 25 marks
Assignment/Quiz/Course project	: 15 marks

End Semester Examination (ESE) Pattern: There will be two parts; Part A and Part B.

Part A : 30 marks

part B : 70 marks

Part A contains 10 questions with 2 questions from each module, having 3 marks for each question. Students should answer all questions.

Part B contains 2 case study questions from each module of which student should answer any one. Each question carry 14 marks and can have maximum 2 sub questions.

Mark distribution

Total Marks	CIE	ESE	ESE Duration
150	50	100	3 hours

Bloom's Category	Continuous Assessment Tests		End Semester Examination
	1	2	
Remember	5	5	10
Understand	10	10	20
Apply	35	35	70
Analyse	-	-	-
Evaluate	-	-	-
Create	-	-	-

Course Level Assessment Questions

Course Outcome 1 (CO1): Appreciate the different concepts and principles involved in design engineering.

1. State how engineering design is different from other kinds of design
2. List the different stages in a design process.
3. Describe design thinking.
4. State the function of prototyping and proofing in engineering design.
5. Write notes on the following concepts in connection with design engineering 1) Modular Design, 2) Life Cycle Design, 3) Value Engineering, 4) Concurrent Engineering, and 5) Reverse Engineering
6. State design rights.

Course Outcome 2 (CO2) Apply design thinking while learning and practicing engineering.

1. Construct the iterative process for design thinking in developing simple products like a pen, umbrella, bag, etc.
2. Show with an example how divergent-convergent thinking helps in generating alternative designs and then how to narrow down to the best design.
3. Describe how a problem-based learning helps in creating better design engineering solutions.
4. Discuss as an engineer, how ethics play a decisive role in your designs

Course Outcome 3 (CO3): Develop innovative, reliable, sustainable and economically viable designs incorporating different segments of knowledge in engineering.

1. Illustrate the development of any simple product by passing through the different stages of design process
2. Show the graphical design communication with the help of detailed 2D or 3D drawings for any simple product.
3. Describe how to develop new designs for simple products through bio-mimicry.

Model Question paper

Page 1 of 2

Reg No.: _____ Name: _____

APJ ABDUL KALAM TECHNOLOGICAL UNIVERSITY**THIRD/FOURTH SEMESTER B.TECH DEGREE EXAMINATION****Course Code: EST 200****Course Name: DESIGN AND ENGINEERING****Max. Marks: 100 Duration: 3 Hours****PART A****Answer all questions, each question carries 3 marks****Use only hand sketches**

- (1) Write about the basic design process.
- (2) Describe how to finalize the design objectives.
- (3) State the role of divergent-convergent questioning in design thinking.
- (4) Discuss how to perform design thinking in a team managing the conflicts.
- (5) Show how engineering sketches and drawings convey designs.
- (6) Explain the role of mathematics and physics in design engineering process.
- (7) Distinguish between project-based learning and problem-based learning in design engineering.
- (8) Describe how concepts like value engineering, concurrent engineering and reverse engineering influence engineering designs?
- (9) Show how designs are varied based on the aspects of production methods, life span, reliability and environment?
- (10) Explain how economics influence the engineering designs?

(10x3 marks =30 marks)**Part B****Answer any ONE question from each module. Each question carry 14 marks****Module 1**

- (11) Show the designing of a wrist watch going through the various stages of the design process. Use hand sketches to illustrate the processes.
- or**
- (12) Find the customer requirements for designing a new car showroom. Show how the design objectives were finalized considering the design constraints?

Module 2

(13) Illustrate the design thinking approach for designing a bag for college students within a limited budget. Describe each stage of the process and the iterative procedure involved. Use hand sketches to support your arguments.

or

(14) Construct a number of possible designs and then refine them to narrow down to the best design for a drug trolley used in hospitals. Show how the divergent-convergent thinking helps in the process. Provide your rationale for each step by using hand sketches only.

Module 3

(15) Graphically communicate the design of a thermo flask used to keep hot coffee. Draw the detailed 2D drawings of the same with design detailing, material selection, scale drawings, dimensions, tolerances, etc. Use only hand sketches.

or

(16) Describe the role of mathematical modelling in design engineering. Show how mathematics and physics play a role in designing a lifting mechanism to raise 100 kg of weight to a floor at a height of 10 meters in a construction site.

Module 4

(17) Show the development of a nature inspired design for a solar powered bus waiting shed beside a highway. Relate between natural and man-made designs. Use hand sketches to support your arguments.

or

(18) Show the design of a simple sofa and then depict how the design changes when considering 1) aesthetics and 2) ergonomics into consideration. Give hand sketches and explanations to justify the changes in designs.

Module 5

(19) Examine the changes in the design of a foot wear with constraints of 1) production methods, 2) life span requirement, 3) reliability issues and 4) environmental factors. Use hand sketches and give proper rationalization for the changes in design.

or

(20) Describe how to estimate the cost of a particular design using ANY of the following:
i) a website, ii) the layout of a plant, iii) the elevation of a building, iv) an electrical or electronic system or device and v) a car.

Show how economics will influence the engineering designs. Use hand sketches to support your arguments.

(5x14 marks =70 marks)

Syllabus

Module 1

Design Process:- Introduction to Design and Engineering Design, Defining a Design Process:-Detailing Customer Requirements, Setting Design Objectives, Identifying Constraints, Establishing Functions, Generating Design Alternatives and Choosing a Design.

Module 2

Design Thinking Approach:-Introduction to Design Thinking, Iterative Design Thinking Process Stages: Empathize, Define, Ideate, Prototype and Test. Design Thinking as Divergent-Convergent Questioning. Design Thinking in a Team Environment.

Module 3

Design Communication (Languages of Engineering Design):-Communicating Designs Graphically, Communicating Designs Orally and in Writing. Mathematical Modeling In Design, Prototyping and Proofing the Design.

Module 4

Design Engineering Concepts:-Project-based Learning and Problem-based Learning in Design.Modular Design and Life Cycle Design Approaches. Application of Biomimicry,Aesthetics and Ergonomics in Design. Value Engineering, Concurrent Engineering, and Reverse Engineering in Design.

Module 5

Expediency, Economics and Environment in Design Engineering:-Design for Production, Use, and Sustainability. Engineering Economics in Design. Design Rights. Ethics in Design

Text Books

- 1) YousefHaik, SangarappillaiSivaloganathan, Tamer M. Shahin, Engineering Design Process, Cengage Learning 2003, Third Edition, ISBN-10: 9781305253285,
- 2) Voland, G., Engineering by Design, Pearson India 2014, Second Edition, ISBN 9332535051

Reference Books

- 1.Philip Kosky, Robert Balmer, William Keat, George Wise, Exploring Engineering, Fourth Edition: An Introduction to Engineering and Design, Academic Press 2015, 4th Edition, ISBN: 9780128012420.
2. Clive L. Dym, Engineering Design: A Project-Based Introduction, John Wiley & Sons, New York 2009, Fourth Edition, ISBN: 978-1-118-32458-5
3. Nigel Cross, Design Thinking: Understanding How Designers Think and Work, Berg Publishers 2011, First Edition, ISBN: 978-1847886361
4. Pahl, G., Beitz, W., Feldhusen, J., Grote, K.-H., Engineering Design: A Systematic Approach, Springer 2007, Third Edition, ISBN 978-1-84628-319-2

Course Contents and Lecture Schedule

No	Topic	No. of Lectures
1	<u>Module 1: Design Process</u>	
1.1	Introduction to Design and Engineering Design. <i>What does it mean to design something? How Is engineering design different from other kinds of design? Where and when do engineers design? What are the basic vocabulary in engineering design? How to learn and do engineering design.</i>	1
1.2	<i>Defining a Design Process-: Detailing Customer Requirements.</i> <i>How to do engineering design? Illustrate the process with an example. How to identify the customer requirements of design?</i>	1
1.3	<i>Defining a Design Process-: Setting Design Objectives, Identifying Constraints, Establishing Functions.</i> <i>How to finalize the design objectives? How to identify the design constraints? How to express the functions a design in engineering terms?</i>	1
1.4	<i>Defining a Design Process-: Generating Design Alternatives and Choosing a Design.</i> <i>How to generate or create feasible design alternatives? How to identify the "best possible design"?</i>	1
1.5	Case Studies:- Stages of Design Process. <i>Conduct exercises for designing simple products going through the different stages of design process.</i>	1
2	<u>Module 2: Design Thinking Approach</u>	
2.1	Introduction to Design Thinking <i>How does the design thinking approach help engineers in creating innovative and efficient designs?</i>	1
2.2	Iterative Design Thinking Process Stages: Empathize, Define, Ideate, Prototype and Test. <i>How can the engineers arrive at better designs utilizing the iterative design thinking process (in which knowledge acquired in the later stages can be applied back to the earlier stages)?</i>	1
2.3	Design Thinking as Divergent-Convergent Questioning. <i>Describe how to create a number of possible designs and then how to refine and narrow down to the 'best design'.</i>	1
2.4	Design Thinking in a Team Environment. <i>How to perform design thinking as a team managing the conflicts ?</i>	1
2.5	Case Studies: Design Thinking Approach. <i>Conduct exercises using the design thinking approach for</i>	1

	<i>designing any simple products within a limited time and budget</i>	
3	<u>Module 3: Design Communication (Languages of Engineering Design)</u>	
3.1	Communicating Designs Graphically. <i>How do engineering sketches and drawings convey designs?</i>	1
3.2	Communicating Designs Orally and in Writing. <i>How can a design be communicated through oral presentation or technical reports efficiently?</i>	1
First Series Examination		
3.3	Mathematical Modelling in Design. <i>How do mathematics and physics become a part of the design process?</i>	1
3.4	Prototyping and Proofing the Design. <i>How to predict whether the design will function well or not?</i>	1
3.5	Case Studies: Communicating Designs Graphically. <i>Conduct exercises for design communication through detailed 2D or 3D drawings of simple products with design detailing, material selection, scale drawings, dimensions, tolerances, etc.</i>	1
4	<u>Module 4: Design Engineering Concepts</u>	
4.1	Project-based Learning and Problem-based Learning in Design. <i>How engineering students can learn design engineering through projects?</i> <i>How students can take up problems to learn design engineering?</i>	1
4.2	Modular Design and Life Cycle Design Approaches. <i>What is modular approach in design engineering? How it helps?</i> <i>How the life cycle design approach influences design decisions?</i>	1
4.3	Application of Bio-mimicry, Aesthetics and Ergonomics in Design. <i>How do aesthetics and ergonomics change engineering designs?</i> <i>How do the intelligence in nature inspire engineering designs? What are the common examples of bio-mimicry in engineering?</i>	1
4.4	Value Engineering, Concurrent Engineering, and Reverse Engineering in Design. <i>How do concepts like value engineering , concurrent engineering and reverse engineering influence engineering designs?</i>	1
4.5	Case Studies: Bio-mimicry based Designs. <i>Conduct exercises to develop new designs for simple</i>	1

	<i>products using bio-mimicry and train students to bring out new nature inspired designs.</i>	
5	<u>Module 5: Expediency, Economics and Environment in Design Engineering</u>	
5.1	Design for Production, Use, and Sustainability. <i>How designs are finalized based on the aspects of production methods, life span, reliability and environment?</i>	1
5.2	Engineering Economics in Design. <i>How to estimate the cost of a particular design and how will economics influence the engineering designs?</i>	1
5.3	Design Rights. <i>What are design rights and how can an engineer put it into practice?</i>	1
5.4	Ethics in Design. <i>How do ethics play a decisive role in engineering design?</i>	1
5.5	Case Studies: Design for Production, Use, and Sustainability. <i>Conduct exercises using simple products to show how designs change with constraints of production methods, life span requirement, reliability issues and environmental factors.</i>	1
Second Series Examination		



Code.	Course Name	L	T	P	Hrs	Credit
HUT 200	Professional Ethics	2	0	0	2	2

Preamble: To enable students to create awareness on ethics and human values.

Prerequisite: Nil

Course Outcomes: After the completion of the course the student will be able to

CO 1	Understand the core values that shape the ethical behaviour of a professional.
CO 2	Adopt a good character and follow an ethical life.
CO 3	Explain the role and responsibility in technological development by keeping personal ethics and legal ethics.
CO 4	Solve moral and ethical problems through exploration and assessment by established experiments.
CO 5	Apply the knowledge of human values and social values to contemporary ethical values and global issues.

Mapping of course outcomes with program outcomes

	PO 1	PO 2	PO 3	PO 4	PO 5	PO 6	PO 7	PO 8	PO 9	PO1 0	PO1 1	PO1 2
CO 1								2			2	
CO 2								2			2	
CO 3								3			2	
CO 4								3			2	
CO 5								3			2	

Assessment Pattern

Bloom's category	Continuous Assessment Tests		End Semester Exam
	1	2	
Remember	15	15	30
Understood	20	20	40
Apply	15	15	30

Mark distribution

Total Marks	CIE	ESE	ESE Duration
150	50	100	3 hours

Continuous Internal Evaluation Pattern:

Attendance	: 10 marks
Continuous Assessment Tests (2 Nos)	: 25 marks
Assignments/Quiz	: 15 marks

End Semester Examination Pattern: There will be two parts; Part A and Part B. Part A contains 10 questions with 2 questions from each module, having 3 marks for each question. Students should answer all questions. Part B contains 2 questions from each module of which student should answer any one. Each question can have maximum 2 sub-divisions and carry 14 marks.

Course Level Assessment Questions**Course Outcome 1 (CO1):**

1. Define integrity and point out ethical values.
2. Describe the qualities required to live a peaceful life.
3. Explain the role of engineers in modern society.

Course Outcome 2 (CO2)

1. Derive the codes of ethics.
2. Differentiate consensus and controversy.
3. Discuss in detail about character and confidence.

Course Outcome 3(CO3):

1. Explain the role of professional's ethics in technological development.
2. Distinguish between self interest and conflicts of interest.
3. Review on industrial standards and legal ethics.

Course Outcome 4 (CO4):

1. Illustrate the role of engineers as experimenters.
2. Interpret the terms safety and risk.
3. Show how the occupational crimes are resolved by keeping the rights of employees.

Course Outcome 5 (CO5):

1. Exemplify the engineers as managers.
2. Investigate the causes and effects of acid rain with a case study.
3. Explore the need of environmental ethics in technological development.

Model Question paper

QP CODE:

Reg No: _____

PAGES:3

Name : _____

**APJ ABDUL KALAM TECHNOLOGICAL UNIVERSITY THIRD/FOURTH SEMESTER
B.TECH DEGREE EXAMINATION, MONTH & YEAR**

Course Code: HUT 200

Course Name: PROFESSIONAL ETHICS

Max. Marks: 100

Duration: 3 Hours

(2019-Scheme)

PART A**(Answer all questions, each question carries 3 marks)**

1. Define empathy and honesty.
2. Briefly explain about morals, values and ethics.
3. Interpret the two forms of self-respect.
4. List out the models of professional roles.
5. Indicate the advantages of using standards.
6. Point out the conditions required to define a valid consent?
7. Identify the conflicts of interests with an example?
8. Recall confidentiality.
9. Conclude the features of biometric ethics.
10. Name any three professional societies and their role relevant to engineers.

(10x3 = 30 marks)

PART B**(Answer one full question from each module, each question carries 14 marks)****MODULE I****11. a)** Classify the relationship between ethical values and law?**b)** Compare between caring and sharing.

(10+4 = 14 marks)

Or**12. a)** Exemplify a comprehensive review about integrity and respect for others.

b) Discuss about co-operation and commitment.

(8+6 = 14 marks)

MODULE II

13.a) Explain the three main levels of moral developments, devised by Kohlberg.

b) Differentiate moral codes and optimal codes.

(10+4 = 14 marks)

Or

14. a) Extrapolate the duty ethics and right ethics.

b) Discuss in detail the three types of inquiries in engineering ethics

(8+6 = 14 marks)

MODULE III

15.a) Summarize the following features of morally responsible engineers.

(i) Moral autonomy

(ii) Accountability

b) Explain the rights of employees

(8+6 = 14 marks)

Or

16. a) Explain the reasons for Chernobyl mishap ?

b) Describe the methods to improve collegiality and loyalty.

(8+6 = 14 marks)

MODULE IV

17.a) Execute collegiality with respect to commitment, respect and connectedness.

b) Identify conflicts of interests with an example.

(8+6 = 14 marks)

Or

18. a) Explain in detail about professional rights and employee rights.

b) Exemplify engineers as managers.

MODULE V

19.a) Evaluate the technology transfer and appropriate technology.

b) Explain about computer and internet ethics.

(8+6 = 14 marks)

Or

20. a) Investigate the causes and effects of acid rain with a case study.

b) Conclude the features of ecocentric and biocentric ethics.

(8+6 = 14 marks)

Syllabus

Module 1 – Human Values.

Morals, values and Ethics – Integrity- Academic integrity-Work Ethics- Service Learning- Civic Virtue- Respect for others- Living peacefully- Caring and Sharing- Honestly- courage-Cooperation commitment- Empathy-Self Confidence -Social Expectations.

Module 2 - Engineering Ethics & Professionalism.

Senses of Engineering Ethics - Variety of moral issues- Types of inquiry- Moral dilemmas –Moral Autonomy – Kohlberg’s theory- Gilligan’s theory- Consensus and Controversy-Profession and Professionalism- Models of professional roles-Theories about right action –Self interest-Customs and Religion- Uses of Ethical Theories.

Module 3- Engineering as social Experimentation.

Engineering as Experimentation – Engineers as responsible Experimenters- Codes of Ethics- Plagiarism- A balanced outlook on law - Challenges case study- Bhopal gas tragedy.

Module 4- Responsibilities and Rights.

Collegiality and loyalty – Managing conflict- Respect for authority- Collective bargaining- Confidentiality- Role of confidentiality in moral integrity-Conflicts of interest- Occupational crime- Professional rights- Employee right- IPR Discrimination.

Module 5- Global Ethical Issues.

Multinational Corporations- Environmental Ethics- Business Ethics- Computer Ethics -Role in Technological Development-Engineers as Managers- Consulting Engineers- Engineers as Expert witnesses and advisors-Moral leadership.

Text Book

1. M Govindarajan, S Natarajan and V S Senthil Kumar, Engineering Ethics, PHI Learning Private Ltd, New Delhi,2012.
2. R S Naagarazan, A text book on professional ethics and human values, New age international (P) limited ,New Delhi,2006.

Reference Books

1. Mike W Martin and Roland Schinzinger, Ethics in Engineering,4th edition, Tata McGraw Hill Publishing Company Pvt Ltd, New Delhi,2014.
2. Charles D Fleddermann, Engineering Ethics, Pearson Education/ Prentice Hall of India, New Jersey,2004.
3. Charles E Harris, Michael S Protchard and Michael J Rabins, Engineering Ethics- Concepts and cases, Wadsworth Thompson Learning, United states,2005.
4. <http://www.slideword.org/slidestag.aspx/human-values-and-Professional-ethics>.

Course Contents and Lecture Schedule

SL.No	Topic	No. of Lectures 25
1	Module 1 – Human Values.	
1.1	Morals, values and Ethics, Integrity, Academic Integrity, Work Ethics	1
1.2	Service Learning, Civic Virtue, Respect for others, Living peacefully	1
1.3	Caring and Sharing, Honesty, Courage, Co-operation commitment	2
1.4	Empathy, Self Confidence, Social Expectations	1
2	Module 2- Engineering Ethics & Professionalism.	
2.1	Senses of Engineering Ethics, Variety of moral issues, Types of inquiry	1
2.2	Moral dilemmas, Moral Autonomy, Kohlberg's theory	1
2.3	Gilligan's theory, Consensus and Controversy, Profession & Professionalism, Models of professional roles, Theories about right action	2
2.4	Self interest-Customs and Religion, Uses of Ethical Theories	1
3	Module 3- Engineering as social Experimentation.	
3.1	Engineering as Experimentation, Engineers as responsible Experimenters	1
3.2	Codes of Ethics, Plagiarism, A balanced outlook on law	2
3.3	Challenger case study, Bhopal gas tragedy	2
4	Module 4- Responsibilities and Rights.	
4.1	Collegiality and loyalty, Managing conflict, Respect for authority	1
4.2	Collective bargaining, Confidentiality, Role of confidentiality in moral integrity, Conflicts of interest	2
4.3	Occupational crime, Professional rights, Employee right, IPR Discrimination	2
5	Module 5- Global Ethical Issues.	
5.1	Multinational Corporations, Environmental Ethics, Business Ethics, Computer Ethics	2
5.2	Role in Technological Development, Moral leadership	1
5.3	Engineers as Managers, Consulting Engineers, Engineers as Expert witnesses and advisors	2

ABDULLAH ABUL KALAM
TECHNOLOGICAL
UNIVERSITY

SEMESTER -4



CODE MCN202	COURSE NAME CONSTITUTION OF INDIA	CATEGORY	L	T	P	CREDIT
			2	0	0	NIL

Preamble:

The study of their own country constitution and studying the importance environment as well as understanding their own human rights help the students to concentrate on their day to day discipline. It also gives the knowledge and strength to face the society and people.

Prerequisite: Nil

Course Outcomes: After the completion of the course the student will be able to

CO 1	Explain the background of the present constitution of India and features.
CO 2	Utilize the fundamental rights and duties.
CO 3	Understand the working of the union executive, parliament and judiciary.
CO 4	Understand the working of the state executive, legislature and judiciary.
CO 5	Utilize the special provisions and statutory institutions.
CO 6	Show national and patriotic spirit as responsible citizens of the country

Mapping of course outcomes with program outcomes

	PO 1	PO 2	PO 3	PO 4	PO 5	PO 6	PO 7	PO 8	PO 9	PO 10	PO 11	PO 12
CO 1						2	2	2		2		
CO 2						3	3	3		3		
CO 3						3	2	3		3		
CO 4						3	2	3		3		
CO 5						3	2	3		3		
CO 6						3	3	3		2		

Assessment Pattern

Bloom's Category	Continuous Assessment Tests		End Semester Examination
	1	2	
Remember	20	20	40
Understand	20	20	40
Apply	10	10	20
Analyse			

Evaluate			
Create			

Mark distribution

Total Marks	CIE	ESE	ESE Duration
150	50	100	3 hours

Continuous Internal Evaluation Pattern:

Attendance	: 10 marks
Continuous Assessment Test (2 numbers)	: 25 marks
Assignment/Quiz/Course project	: 15 marks

End Semester Examination Pattern: There will be two parts; Part A and Part B. Part A contain 10 questions with 2 questions from each module, having 3 marks for each question. Students should answer all questions. Part B contains 2 questions from each module of which student should answer any one. Each question can have maximum 2 sub-divisions and carry 14 marks.

Course Level Assessment Questions**Course Outcome 1 (CO1):**

- 1 Discuss the historical background of the Indian constitution.
- 2 Explain the salient features of the Indian constitution.
- 3 Discuss the importance of preamble in the implementation of constitution.

Course Outcome 2 (CO2)

- 1 What are fundamental rights ? Examine each of them.
- 2 Examine the scope of freedom of speech and expression underlying the constitution.
- 3 The thumb impression of an accused is taken by the police against his will. He contends that this is a violation of his rights under Art 20(3) of the constitution. Decide.

Course Outcome 3(CO3):

- 1 Explain the powers of the President to suspend the fundamental rights during emergency.

- 2 Explain the salient features of appeal by special leave.
3. List the constitutional powers of President.

Course Outcome 4 (CO4):

- 1 Discuss the constitutional powers of Governor.
- 2 Examine the writ jurisdiction of High court.
- 3 Discuss the qualification and disqualification of membership of state legislature.

Course Outcome 5 (CO5):

- 1 Discuss the duties and powers of comptroller of auditor general.
- 2 Discuss the proclamation of emergency.
- 3 A state levies tax on motor vehicles used in the state, for the purpose of maintaining roads in the state. X challenges the levy of the tax on the ground that it violates the freedom of interstate commerce guaranteed under Art 301. Decide.

Course Outcome 6 (CO6):

- 1 Explain the advantages of citizenship.
- 2 List the important principles contained in the directive principles of state policy.
- 3 Discuss the various aspects contained in the preamble of the constitution

Model Question paper**PART A**

(Answer all questions. Each question carries 3 marks)

- 1 Define and explain the term constitution.
- 2 Explain the need and importance of Preamble.
- 3 What is directive principle of state policy?
- 4 Define the State.
- 5 List the functions of Attorney general of India.

- 6 Explain the review power of Supreme court.
- 7 List the qualifications of Governor.
- 8 Explain the term and removal of Judges in High court.
- 9 Explain the powers of public service commission.
- 10 List three types of emergency under Indian constitution.

(10X3=30marks)

PART B

(Answer on question from each module. Each question carries 14 marks)

Module 1

- 11 Discuss the various methods of acquiring Indian citizenship.
- 12 Examine the salient features of the Indian constitution.

Module 2

- 13 A high court passes a judgement against X. X desires to file a writ petition in the supreme court under Art32, on the ground that the judgement violates his fundamental rights. Advise him whether he can do so.
- 14 What is meant by directive principles of State policy? List the directives.

Module3

- 15 Describe the procedure of election and removal of the President of India.
- 16 Supreme court may in its discretion grant special leave to appeal. Examine the situation.

Module 4

- 17 Discuss the powers of Governor.
- 18 X filed a writ petition under Art 226 which was dismissed. Subsequently, he filed a writ petition under Art 32 of the constitution, seeking the same remedy. The Government argued that the writ petition should be dismissed, on the ground of res judicata. Decide.

Module 5

19 Examine the scope of the financial relations between the union and the states.

20 Discuss the effects of proclamation of emergency.

(14X5=70marks)

Syllabus

Module 1 Definition, historical back ground, features, preamble, territory, citizenship.

Module 2 State, fundamental rights, directive principles, duties.

Module 3 The machinery of the union government.

Module 4 Government machinery in the states

Module 5 The federal system, Statutory Institutions, miscellaneous provisions.

Text Books

1 D D Basu, Introduction to the constitution of India, Lexis Nexis, New Delhi, 24e, 2019

2 PM Bhakshi, The constitution of India, Universal Law, 14e, 2017

Reference Books

1 Ministry of law and justice, The constitution of India, Govt of India, New Delhi, 2019.

2 JN Pandey, The constitutional law of India, Central Law agency, Allahabad, 51e, 2019

3 MV Pylee, India's Constitution, S Chand and company, New Delhi, 16e, 2016

Course Contents and Lecture Schedule

No	Topic	No. of Lectures
1	Module 1	
1.1	Definition of constitution, historical back ground, salient features of the constitution.	1
1.2	Preamble of the constitution, union and its territory.	1
1.3	Meaning of citizenship, types, termination of citizenship.	2
2	Module 2	
2.1	Definition of state, fundamental rights, general nature, classification, right to equality ,right to freedom , right against exploitation	2

2.2	Right to freedom of religion, cultural and educational rights, right to constitutional remedies. Protection in respect of conviction for offences.	2
2.3	Directive principles of state policy, classification of directives, fundamental duties.	2
3	Module 3	
3.1	The Union executive, the President, the vice President, the council of ministers, the Prime minister, Attorney-General, functions.	2
3.2	The parliament, composition, Rajya sabha, Lok sabha, qualification and disqualification of membership, functions of parliament.	2
3.3	Union judiciary, the supreme court, jurisdiction, appeal by special leave.	1
4	Module 4	
4.1	The State executive, the Governor, the council of ministers, the Chief minister, advocate general, union Territories.	2
4.2	The State Legislature, composition, qualification and disqualification of membership, functions.	2
4.3	The state judiciary, the high court, jurisdiction, writs jurisdiction.	1
5	Module 5	
5.1	Relations between the Union and the States, legislative relation, administrative relation, financial Relations, Inter State council, finance commission.	1
5.2	Emergency provision, freedom of trade commerce and inter course, comptroller and auditor general of India, public Services, public service commission, administrative Tribunals.	2
5.3	Official language, elections, special provisions relating to certain classes, amendment of the Constitution.	2

CODE	COURSE NAME	CATEGORY	L	T	P	CREDIT
					2	0
EST 200	DESIGN AND ENGINEERING					

Preamble:

The purpose of this course is to

- i) introduce the undergraduate engineering students the fundamental principles of design engineering,
- ii) make them understand the steps involved in the design process and
- iii) familiarize them with the basic tools used and approaches in design.

Students are expected to apply design thinking in learning as well as while practicing engineering, which is very important and relevant for today. Case studies from various practical situations will help the students realize that design is not only concerned about the function but also many other factors like customer requirements, economics, reliability, etc. along with a variety of life cycle issues.

The course will help students to consider aesthetics, ergonomics and sustainability factors in designs and also to practice professional ethics while designing.

Prerequisite:

Nil. The course will be generic to all engineering disciplines and will not require specialized preparation or prerequisites in any of the individual engineering disciplines.

Course Outcomes:

After the completion of the course the student will be able to

CO 1	Explain the different concepts and principles involved in design engineering.
CO 2	Apply design thinking while learning and practicing engineering.
CO 3	Develop innovative, reliable, sustainable and economically viable designs incorporating knowledge in engineering.

Mapping of course outcomes with program outcomes

	PO 1	PO 2	PO 3	PO 4	PO 5	PO 6	PO 7	PO 8	PO 9	PO 10	PO 11	PO 12
CO 1	2	1					1			1		
CO 2		2				1		1				2
CO 3			2			1	1		2	2		1

Assessment Pattern**Continuous Internal Evaluation (CIE) Pattern:**

Attendance	: 10 marks
Continuous Assessment Test (2 numbers)	: 25 marks
Assignment/Quiz/Course project	: 15 marks

End Semester Examination (ESE) Pattern: There will be two parts; Part A and Part B.

Part A : 30 marks

part B : 70 marks

Part A contains 10 questions with 2 questions from each module, having 3 marks for each question. Students should answer all questions.

Part B contains 2 case study questions from each module of which student should answer any one. Each question carry 14 marks and can have maximum 2 sub questions.

Mark distribution

Total Marks	CIE	ESE	ESE Duration
150	50	100	3 hours

Bloom's Category	Continuous Assessment Tests		End Semester Examination
	1	2	
Remember	5	5	10
Understand	10	10	20
Apply	35	35	70
Analyse	-	-	-
Evaluate	-	-	-
Create	-	-	-

Course Level Assessment Questions

Course Outcome 1 (CO1): Appreciate the different concepts and principles involved in design engineering.

1. State how engineering design is different from other kinds of design
2. List the different stages in a design process.
3. Describe design thinking.
4. State the function of prototyping and proofing in engineering design.
5. Write notes on the following concepts in connection with design engineering 1) Modular Design, 2) Life Cycle Design, 3) Value Engineering, 4) Concurrent Engineering, and 5) Reverse Engineering
6. State design rights.

Course Outcome 2 (CO2) Apply design thinking while learning and practicing engineering.

1. Construct the iterative process for design thinking in developing simple products like a pen, umbrella, bag, etc.
2. Show with an example how divergent-convergent thinking helps in generating alternative designs and then how to narrow down to the best design.
3. Describe how a problem-based learning helps in creating better design engineering solutions.
4. Discuss as an engineer, how ethics play a decisive role in your designs

Course Outcome 3 (CO3): Develop innovative, reliable, sustainable and economically viable designs incorporating different segments of knowledge in engineering.

1. Illustrate the development of any simple product by passing through the different stages of design process
2. Show the graphical design communication with the help of detailed 2D or 3D drawings for any simple product.
3. Describe how to develop new designs for simple products through bio-mimicry.

Model Question paper

Page 1 of 2

Reg No.: _____ Name: _____

**APJ ABDUL KALAM TECHNOLOGICAL UNIVERSITY
THIRD/FOURTH SEMESTER B.TECH DEGREE EXAMINATION**

Course Code: EST 200

Course Name: DESIGN AND ENGINEERING

Max. Marks: 100 Duration: 3 Hours

PART A**Answer all questions, each question carries 3 marks****Use only hand sketches**

- (1) Write about the basic design process.
- (2) Describe how to finalize the design objectives.
- (3) State the role of divergent-convergent questioning in design thinking.
- (4) Discuss how to perform design thinking in a team managing the conflicts.
- (5) Show how engineering sketches and drawings convey designs.
- (6) Explain the role of mathematics and physics in design engineering process.
- (7) Distinguish between project-based learning and problem-based learning in design engineering.
- (8) Describe how concepts like value engineering, concurrent engineering and reverse engineering influence engineering designs?
- (9) Show how designs are varied based on the aspects of production methods, life span, reliability and environment?
- (10) Explain how economics influence the engineering designs?

(10x3 marks =30 marks)**Part B****Answer any ONE question from each module. Each question carry 14 marks****Module 1**

- (11) Show the designing of a wrist watch going through the various stages of the design process. Use hand sketches to illustrate the processes.
- or**
- (12) Find the customer requirements for designing a new car showroom. Show how the design objectives were finalized considering the design constraints?

Module 2

(13) Illustrate the design thinking approach for designing a bag for college students within a limited budget. Describe each stage of the process and the iterative procedure involved. Use hand sketches to support your arguments.

or

(14) Construct a number of possible designs and then refine them to narrow down to the best design for a drug trolley used in hospitals. Show how the divergent-convergent thinking helps in the process. Provide your rationale for each step by using hand sketches only.

Module 3

(15) Graphically communicate the design of a thermo flask used to keep hot coffee. Draw the detailed 2D drawings of the same with design detailing, material selection, scale drawings, dimensions, tolerances, etc. Use only hand sketches.

or

(16) Describe the role of mathematical modelling in design engineering. Show how mathematics and physics play a role in designing a lifting mechanism to raise 100 kg of weight to a floor at a height of 10 meters in a construction site.

Module 4

(17) Show the development of a nature inspired design for a solar powered bus waiting shed beside a highway. Relate between natural and man-made designs. Use hand sketches to support your arguments.

or

(18) Show the design of a simple sofa and then depict how the design changes when considering 1) aesthetics and 2) ergonomics into consideration. Give hand sketches and explanations to justify the changes in designs.

Module 5

(19) Examine the changes in the design of a foot wear with constraints of 1) production methods, 2) life span requirement, 3) reliability issues and 4) environmental factors. Use hand sketches and give proper rationalization for the changes in design.

or

(20) Describe how to estimate the cost of a particular design using ANY of the following:
i) a website, ii) the layout of a plant, iii) the elevation of a building, iv) an electrical or electronic system or device and v) a car.

Show how economics will influence the engineering designs. Use hand sketches to support your arguments.

(5x14 marks =70 marks)

Syllabus

Module 1

Design Process:- Introduction to Design and Engineering Design, Defining a Design Process:-Detailing Customer Requirements, Setting Design Objectives, Identifying Constraints, Establishing Functions, Generating Design Alternatives and Choosing a Design.

Module 2

Design Thinking Approach:-Introduction to Design Thinking, Iterative Design Thinking Process Stages: Empathize, Define, Ideate, Prototype and Test. Design Thinking as Divergent-Convergent Questioning. Design Thinking in a Team Environment.

Module 3

Design Communication (Languages of Engineering Design):-Communicating Designs Graphically, Communicating Designs Orally and in Writing. Mathematical Modeling In Design, Prototyping and Proofing the Design.

Module 4

Design Engineering Concepts:-Project-based Learning and Problem-based Learning in Design.Modular Design and Life Cycle Design Approaches. Application of Biomimicry,Aesthetics and Ergonomics in Design. Value Engineering, Concurrent Engineering, and Reverse Engineering in Design.

Module 5

Expediency, Economics and Environment in Design Engineering:-Design for Production, Use, and Sustainability. Engineering Economics in Design. Design Rights. Ethics in Design

Text Books

- 1) YousefHaik, SangarappillaiSivaloganathan, Tamer M. Shahin, Engineering Design Process, Cengage Learning 2003, Third Edition, ISBN-10: 9781305253285,
- 2) Voland, G., Engineering by Design, Pearson India 2014, Second Edition, ISBN 9332535051

Reference Books

- 1.Philip Kosky, Robert Balmer, William Keat, George Wise, Exploring Engineering, Fourth Edition: An Introduction to Engineering and Design, Academic Press 2015, 4th Edition, ISBN: 9780128012420.
2. Clive L. Dym, Engineering Design: A Project-Based Introduction, John Wiley & Sons, New York 2009, Fourth Edition, ISBN: 978-1-118-32458-5
3. Nigel Cross, Design Thinking: Understanding How Designers Think and Work, Berg Publishers 2011, First Edition, ISBN: 978-1847886361
4. Pahl, G., Beitz, W., Feldhusen, J., Grote, K.-H., Engineering Design: A Systematic Approach, Springer 2007, Third Edition, ISBN 978-1-84628-319-2

Course Contents and Lecture Schedule

No	Topic	No. of Lectures
1	<u>Module 1: Design Process</u>	
1.1	Introduction to Design and Engineering Design. <i>What does it mean to design something? How Is engineering design different from other kinds of design? Where and when do engineers design? What are the basic vocabulary in engineering design? How to learn and do engineering design.</i>	1
1.2	<i>Defining a Design Process-: Detailing Customer Requirements.</i> <i>How to do engineering design? Illustrate the process with an example. How to identify the customer requirements of design?</i>	1
1.3	<i>Defining a Design Process-: Setting Design Objectives, Identifying Constraints, Establishing Functions.</i> <i>How to finalize the design objectives? How to identify the design constraints? How to express the functions a design in engineering terms?</i>	1
1.4	<i>Defining a Design Process-: Generating Design Alternatives and Choosing a Design.</i> <i>How to generate or create feasible design alternatives? How to identify the "best possible design"?</i>	1
1.5	Case Studies:- Stages of Design Process. <i>Conduct exercises for designing simple products going through the different stages of design process.</i>	1
2	<u>Module 2: Design Thinking Approach</u>	
2.1	Introduction to Design Thinking <i>How does the design thinking approach help engineers in creating innovative and efficient designs?</i>	1
2.2	Iterative Design Thinking Process Stages: Empathize, Define, Ideate, Prototype and Test. <i>How can the engineers arrive at better designs utilizing the iterative design thinking process (in which knowledge acquired in the later stages can be applied back to the earlier stages)?</i>	1
2.3	Design Thinking as Divergent-Convergent Questioning. <i>Describe how to create a number of possible designs and then how to refine and narrow down to the 'best design'.</i>	1
2.4	Design Thinking in a Team Environment. <i>How to perform design thinking as a team managing the conflicts ?</i>	1
2.5	Case Studies: Design Thinking Approach. <i>Conduct exercises using the design thinking approach for</i>	1

	<i>designing any simple products within a limited time and budget</i>	
3	<u>Module 3: Design Communication (Languages of Engineering Design)</u>	
3.1	Communicating Designs Graphically. <i>How do engineering sketches and drawings convey designs?</i>	1
3.2	Communicating Designs Orally and in Writing. <i>How can a design be communicated through oral presentation or technical reports efficiently?</i>	1
First Series Examination		
3.3	Mathematical Modelling in Design. <i>How do mathematics and physics become a part of the design process?</i>	1
3.4	Prototyping and Proofing the Design. <i>How to predict whether the design will function well or not?</i>	1
3.5	Case Studies: Communicating Designs Graphically. <i>Conduct exercises for design communication through detailed 2D or 3D drawings of simple products with design detailing, material selection, scale drawings, dimensions, tolerances, etc.</i>	1
4	<u>Module 4: Design Engineering Concepts</u>	
4.1	Project-based Learning and Problem-based Learning in Design. <i>How engineering students can learn design engineering through projects?</i> <i>How students can take up problems to learn design engineering?</i>	1
4.2	Modular Design and Life Cycle Design Approaches. <i>What is modular approach in design engineering? How it helps?</i> <i>How the life cycle design approach influences design decisions?</i>	1
4.3	Application of Bio-mimicry, Aesthetics and Ergonomics in Design. <i>How do aesthetics and ergonomics change engineering designs?</i> <i>How do the intelligence in nature inspire engineering designs? What are the common examples of bio-mimicry in engineering?</i>	1
4.4	Value Engineering, Concurrent Engineering, and Reverse Engineering in Design. <i>How do concepts like value engineering , concurrent engineering and reverse engineering influence engineering designs?</i>	1
4.5	Case Studies: Bio-mimicry based Designs. <i>Conduct exercises to develop new designs for simple</i>	1

	<i>products using bio-mimicry and train students to bring out new nature inspired designs.</i>	
5	<u>Module 5: Expediency, Economics and Environment in Design Engineering</u>	
5.1	Design for Production, Use, and Sustainability. <i>How designs are finalized based on the aspects of production methods, life span, reliability and environment?</i>	1
5.2	Engineering Economics in Design. <i>How to estimate the cost of a particular design and how will economics influence the engineering designs?</i>	1
5.3	Design Rights. <i>What are design rights and how can an engineer put it into practice?</i>	1
5.4	Ethics in Design. <i>How do ethics play a decisive role in engineering design?</i>	1
5.5	Case Studies: Design for Production, Use, and Sustainability. <i>Conduct exercises using simple products to show how designs change with constraints of production methods, life span requirement, reliability issues and environmental factors.</i>	1
Second Series Examination		



Code.	Course Name	L	T	P	Hrs	Credit
HUT 200	Professional Ethics	2	0	0	2	2

Preamble: To enable students to create awareness on ethics and human values.

Prerequisite: Nil

Course Outcomes: After the completion of the course the student will be able to

CO 1	Understand the core values that shape the ethical behaviour of a professional.
CO 2	Adopt a good character and follow an ethical life.
CO 3	Explain the role and responsibility in technological development by keeping personal ethics and legal ethics.
CO 4	Solve moral and ethical problems through exploration and assessment by established experiments.
CO 5	Apply the knowledge of human values and social values to contemporary ethical values and global issues.

Mapping of course outcomes with program outcomes

	PO 1	PO 2	PO 3	PO 4	PO 5	PO 6	PO 7	PO 8	PO 9	PO1 0	PO1 1	PO1 2
CO 1								2			2	
CO 2								2			2	
CO 3								3			2	
CO 4								3			2	
CO 5								3			2	

Assessment Pattern

Bloom's category	Continuous Assessment Tests		End Semester Exam
	1	2	
Remember	15	15	30
Understood	20	20	40
Apply	15	15	30

Mark distribution

Total Marks	CIE	ESE	ESE Duration
150	50	100	3 hours

Continuous Internal Evaluation Pattern:

Attendance	: 10 marks
Continuous Assessment Tests (2 Nos)	: 25 marks
Assignments/Quiz	: 15 marks

End Semester Examination Pattern: There will be two parts; Part A and Part B. Part A contains 10 questions with 2 questions from each module, having 3 marks for each question. Students should answer all questions. Part B contains 2 questions from each module of which student should answer any one. Each question can have maximum 2 sub-divisions and carry 14 marks.

Course Level Assessment Questions**Course Outcome 1 (CO1):**

1. Define integrity and point out ethical values.
2. Describe the qualities required to live a peaceful life.
3. Explain the role of engineers in modern society.

Course Outcome 2 (CO2)

1. Derive the codes of ethics.
2. Differentiate consensus and controversy.
3. Discuss in detail about character and confidence.

Course Outcome 3(CO3):

1. Explain the role of professional's ethics in technological development.
2. Distinguish between self interest and conflicts of interest.
3. Review on industrial standards and legal ethics.

Course Outcome 4 (CO4):

1. Illustrate the role of engineers as experimenters.
2. Interpret the terms safety and risk.
3. Show how the occupational crimes are resolved by keeping the rights of employees.

Course Outcome 5 (CO5):

1. Exemplify the engineers as managers.
2. Investigate the causes and effects of acid rain with a case study.
3. Explore the need of environmental ethics in technological development.

Model Question paper

QP CODE:

Reg No: _____

PAGES:3

Name : _____

**APJ ABDUL KALAM TECHNOLOGICAL UNIVERSITY THIRD/FOURTH SEMESTER
B.TECH DEGREE EXAMINATION, MONTH & YEAR**

Course Code: HUT 200

Course Name: PROFESSIONAL ETHICS

Max. Marks: 100

Duration: 3 Hours

(2019-Scheme)

PART A**(Answer all questions, each question carries 3 marks)**

1. Define empathy and honesty.
2. Briefly explain about morals, values and ethics.
3. Interpret the two forms of self-respect.
4. List out the models of professional roles.
5. Indicate the advantages of using standards.
6. Point out the conditions required to define a valid consent?
7. Identify the conflicts of interests with an example?
8. Recall confidentiality.
9. Conclude the features of biometric ethics.
10. Name any three professional societies and their role relevant to engineers.

(10x3 = 30 marks)

PART B**(Answer one full question from each module, each question carries 14 marks)****MODULE I****11. a)** Classify the relationship between ethical values and law?**b)** Compare between caring and sharing.

(10+4 = 14 marks)

Or**12. a)** Exemplify a comprehensive review about integrity and respect for others.

b) Discuss about co-operation and commitment.

(8+6 = 14 marks)

MODULE II

13.a) Explain the three main levels of moral developments, devised by Kohlberg.

b) Differentiate moral codes and optimal codes.

(10+4 = 14 marks)

Or

14. a) Extrapolate the duty ethics and right ethics.

b) Discuss in detail the three types of inquiries in engineering ethics

(8+6 = 14 marks)

MODULE III

15.a) Summarize the following features of morally responsible engineers.

(i) Moral autonomy

(ii) Accountability

b) Explain the rights of employees

(8+6 = 14 marks)

Or

16. a) Explain the reasons for Chernobyl mishap ?

b) Describe the methods to improve collegiality and loyalty.

(8+6 = 14 marks)

MODULE IV

17.a) Execute collegiality with respect to commitment, respect and connectedness.

b) Identify conflicts of interests with an example.

(8+6 = 14 marks)

Or

18. a) Explain in detail about professional rights and employee rights.

b) Exemplify engineers as managers.

MODULE V

19.a) Evaluate the technology transfer and appropriate technology.

b) Explain about computer and internet ethics.

(8+6 = 14 marks)

Or

20. a) Investigate the causes and effects of acid rain with a case study.

b) Conclude the features of ecocentric and biocentric ethics.

(8+6 = 14 marks)

Syllabus

Module 1 – Human Values.

Morals, values and Ethics – Integrity- Academic integrity-Work Ethics- Service Learning- Civic Virtue- Respect for others- Living peacefully- Caring and Sharing- Honestly- courage-Cooperation commitment- Empathy-Self Confidence -Social Expectations.

Module 2 - Engineering Ethics & Professionalism.

Senses of Engineering Ethics - Variety of moral issues- Types of inquiry- Moral dilemmas –Moral Autonomy – Kohlberg’s theory- Gilligan’s theory- Consensus and Controversy-Profession and Professionalism- Models of professional roles-Theories about right action –Self interest-Customs and Religion- Uses of Ethical Theories.

Module 3- Engineering as social Experimentation.

Engineering as Experimentation – Engineers as responsible Experimenters- Codes of Ethics- Plagiarism- A balanced outlook on law - Challenges case study- Bhopal gas tragedy.

Module 4- Responsibilities and Rights.

Collegiality and loyalty – Managing conflict- Respect for authority- Collective bargaining- Confidentiality- Role of confidentiality in moral integrity-Conflicts of interest- Occupational crime- Professional rights- Employee right- IPR Discrimination.

Module 5- Global Ethical Issues.

Multinational Corporations- Environmental Ethics- Business Ethics- Computer Ethics -Role in Technological Development-Engineers as Managers- Consulting Engineers- Engineers as Expert witnesses and advisors-Moral leadership.

Text Book

1. M Govindarajan, S Natarajan and V S Senthil Kumar, Engineering Ethics, PHI Learning Private Ltd, New Delhi,2012.
2. R S Naagarazan, A text book on professional ethics and human values, New age international (P) limited ,New Delhi,2006.

Reference Books

1. Mike W Martin and Roland Schinzinger, Ethics in Engineering,4th edition, Tata McGraw Hill Publishing Company Pvt Ltd, New Delhi,2014.
2. Charles D Fleddermann, Engineering Ethics, Pearson Education/ Prentice Hall of India, New Jersey,2004.
3. Charles E Harris, Michael S Protchard and Michael J Rabins, Engineering Ethics- Concepts and cases, Wadsworth Thompson Learning, United states,2005.
4. <http://www.slideword.org/slidestag.aspx/human-values-and-Professional-ethics>.

Course Contents and Lecture Schedule

SL.No	Topic	No. of Lectures 25
1	Module 1 – Human Values.	
1.1	Morals, values and Ethics, Integrity, Academic Integrity, Work Ethics	1
1.2	Service Learning, Civic Virtue, Respect for others, Living peacefully	1
1.3	Caring and Sharing, Honesty, Courage, Co-operation commitment	2
1.4	Empathy, Self Confidence, Social Expectations	1
2	Module 2- Engineering Ethics & Professionalism.	
2.1	Senses of Engineering Ethics, Variety of moral issues, Types of inquiry	1
2.2	Moral dilemmas, Moral Autonomy, Kohlberg's theory	1
2.3	Gilligan's theory, Consensus and Controversy, Profession & Professionalism, Models of professional roles, Theories about right action	2
2.4	Self interest-Customs and Religion, Uses of Ethical Theories	1
3	Module 3- Engineering as social Experimentation.	
3.1	Engineering as Experimentation, Engineers as responsible Experimenters	1
3.2	Codes of Ethics, Plagiarism, A balanced outlook on law	2
3.3	Challenger case study, Bhopal gas tragedy	2
4	Module 4- Responsibilities and Rights.	
4.1	Collegiality and loyalty, Managing conflict, Respect for authority	1
4.2	Collective bargaining, Confidentiality, Role of confidentiality in moral integrity, Conflicts of interest	2
4.3	Occupational crime, Professional rights, Employee right, IPR Discrimination	2
5	Module 5- Global Ethical Issues.	
5.1	Multinational Corporations, Environmental Ethics, Business Ethics, Computer Ethics	2
5.2	Role in Technological Development, Moral leadership	1
5.3	Engineers as Managers, Consulting Engineers, Engineers as Expert witnesses and advisors	2